



GENERAL REQUIREMENTS FOR DISTRIBUTED GENERATION

EFFECTIVE: May 1, 2022
Revised March 12, 2026

**GrandBridge Energy Inc.
GENERAL REQUIREMENTS
FOR DISTRIBUTED GENERATION**

Table of Contents

1	INTRODUCTION	4
2	GENERAL REQUIREMENTS	4
3	CONNECTION PROCESS	5
3.1	MICRO-DISTRIBUTED GENERATION (<=12kW)	5
3.1.1	Request for Information	5
3.1.2	Provision of Information	6
3.1.3	Development of Generation Plan	6
3.1.4	Application Process	6
3.1.5	ESA Electrical Inspection Application	6
3.1.6	GBE Review of Application	6
3.1.6.1	For Generator at Existing Customer Connection	6
3.1.6.2	For Generator Not at Existing Customer Connection	6
3.1.7	Decision to Proceed	7
3.1.8	Final Connection	7
3.2	GENERATION > 12kW	7
3.2.1	Initial Contact	8
3.2.2	Provision of Information	8
3.2.3	Development of Generation Plan	8
3.2.4	Initial Consultation (No Charge)	8
3.2.5	Application for Connection Impact Assessment	9
3.2.6	Connection Impact Assessment	9
3.2.6.1	Timing	9
3.2.7	Decision to Proceed	10
3.2.7.1	Small	10
3.2.7.2	Mid-Sized and Large	10
3.2.8	Implementation	11
3.2.9	New Account Application, Sales Tax Form, and Connection Agreement	12
3.2.10	Commissioning and Verification	13
3.2.11	Completion	13
4	GENERAL TECHNICAL REQUIREMENTS	13
4.1	CONNECTION POINT	13
4.1.1	Interconnection Switch	13
4.1.2	GBE Access	13
4.1.3	Fault Interrupting Devices	14
4.1.4	Generation Connection Point	14
4.1.5	Point Of Isolation	14
4.1.6	Supervisory Control	14
4.2	VOLTAGE	14
4.2.1	Primary Distribution Voltage Level	14
4.2.2	Interface Transformer	15

4.2.3	Voltage Regulation	15
4.3	PROTECTION SYSTEM	15
4.3.1	Protection System Goals	15
4.3.2	Interface Protection Requirements.....	16
4.3.2.1	Ground Fault Protection	16
4.3.2.2	Phase Fault Protection	16
4.3.2.3	Protection for Islanding/Abnormal conditions	17
4.3.3	Relay Types and Settings.....	17
4.3.4	Fault Levels and Protection Coordination	17
4.3.5	Generator/Interface Circuit Breaker	17
4.3.6	Synchronizing	18
4.3.7	GBE Breaker Reclosing Scheme	18
4.3.8	Transfer Trip Protection Requirement	18
4.3.9	Protection System Failure	19
4.4	TYPE OF GENERATION	19
4.4.1	Induction Generator	19
4.4.2	Synchronous Generator.....	20
4.4.3	Inverter Type Generator.....	20
4.5	POWER QUALITY	20
4.5.1	Design Goals.....	20
4.5.2	Power Quality Requirements	21
4.5.3	Future Requirements.....	21
4.5.4	Phase Unbalance	21
4.5.5	Frequency.....	21
4.5.6	Voltage Flicker.....	21
4.5.7	Power Factor	21
4.6	METERING	22
4.6.1	Metering Requirements.....	22
4.6.2	Metering Instrument Transformers.....	22
4.7	SYSTEM CHANGE	23
4.8	SYSTEM DOCUMENTATION	23
4.9	WARNING NOTICES AND DIAGRAMS.....	23
4.10	VERIFICATION OF PROTECTION SYSTEM	24
4.11	INSPECTION REQUIREMENTS.....	24
4.12	PERFORMANCE UNDER THIS SPECIFICATION	24
4.13	LIABILITY	25
5	NET METERING	26
5.1	What is Net Metering?	26
5.2	How will your hydro bill be calculated?	26
5.3	Who is eligible?.....	27
5.4	How do you get started?.....	27
6	IESO FEED IN TARIFF PROGRAMS.....	27

Appendixes

Appendix 1: Micro-Distributed Generation Application Form

Appendix 2: Micro-Distributed Generation Facility Connection Agreement

Appendix 3: New Generation Account Application Form

Appendix 4: Preliminary Consultation Information Request Form

Appendix 5: Connection Impact Assessment Application Form

GRANDBRIDGE ENERGY INC. GENERAL REQUIREMENTS FOR

DISTRIBUTED GENERATION

1 INTRODUCTION

GrandBridge Energy Inc. (GBE) Inc. is a corporation incorporated under the laws of the Province of Ontario and a Distributor of electricity.

This document describes the general requirements for connecting a distributed generator (DG) to the GBE distribution system. These requirements are regulated by the Ontario Energy Board (OEB) (www.oeb.gov.on.ca) and are partially detailed in the OEB's Distribution System Code (DSC). The DSC sets the minimum obligations that a licensed electricity distributor must meet in carrying out its obligations to distribute electricity within its Service Area under its license and the *Energy Competition Act*.

This document is in addition to the requirements of GBE's Conditions of Service and all other requirements of GBE. The Generator agrees to comply with all requirements as amended by GBE from time to time.

For inquiries relating to the connection of distributed generation facilities, please contact: generation@grandbridgeenergy.com

If at any time the Generator feels that GBE is not being fair and reasonable, the Generator may request a review by GBE using the dispute resolution process outlined in GBE's Conditions of Service (section 1.8).

2 GENERAL REQUIREMENTS

The following general requirements must be met by the Generator:

1. The health and safety of the general public, utility personnel (or its agents) and the Generator's personnel must not be compromised or adversely affected in any way.
2. The Generator must not adversely affect or compromise equipment owned or operated by GBE (and Hydro One who is our transmitter, where applicable) nor the security, reliability and the quality of electrical supply of other customers connected to the GBE distribution system.

3. The Generator must meet all of GBE's requirements (and any Hydro One and/or IESO (www.ieso.ca) requirements (if applicable)) and comply with the Electrical Safety Code (as administered by the Electrical Safety Authority (ESA)).

Under no circumstances will the Generator be allowed to connect to the GBE distribution system unless GBE's requirements are met. If at any time these requirements are not met, GBE will have the right to refuse connection or to immediately disconnect the Generator from the GBE distribution system.

The Generator shall be responsible for ensuring that:

1. Appropriately certified and rated equipment is correctly installed;
2. Personnel involved in operating and maintaining the DG are qualified (i.e. knowledgeable and properly trained in operation and safe working procedures);
3. Maintenance is carried out on a regular basis by qualified personnel;
4. All necessary and required care is taken to protect the public, utility personnel (or its agents) and the Generator's personnel from hazards associated with the generation system of the DG;
5. The Generator's Facilities are inspected and approved by the ESA;
6. The installations, connections and operations meet all the requirements of Hydro One (our transmitter), the IESO, (if applicable), federal, provincial, and municipal statutes, regulations, bylaws, and codes, that pertain to the DG; and
7. It obtains the necessary licences and permits to install and operate the DG.

3 CONNECTION PROCESS

Subject to all applicable laws, regulations and codes, GBE will make all reasonable efforts to promptly connect a generation facility to its distribution system.

3.1 MICRO-DISTRIBUTED GENERATION (<=12kW)

The connection process for Micro-Distributed Generation (<= 12kW) is as follows:

3.1.1 Request for Information

The Generator proposing the installation of a Micro-Distributed generation facility contacts GBE and the ESA for information.

3.1.2 Provision of Information

GBE provides a copy of this document to the Generator to outline the connection process, required approvals, technical requirements (including metering), application form and contractual requirements.

The ESA is responsible for provision of information on electrical safety requirements. The ESA can be contacted at 1-877-ESA- SAFE (1-877-372-7233). The ESA's web site is www.esainspection.net. The ESA has published a booklet entitled "Electrical Guidelines for Inverter-Based Micro-Generating Facility (12kW and Smaller)" which is a useful guide.

3.1.3 Development of Generation Plan

The Generator reviews the relevant information from GBE and the ESA and puts together an installation plan.

3.1.4 Application Process

The Generator submits an application, Appendix 1 and Appendix 4, to GBE for an Offer to Connect. GBE will make an Offer to Connect or provide reasons for refusing to connect the proposed generation facility within 15 calendar days. The Offer to Connect is good for 6 months.

3.1.5 ESA Electrical Inspection Application

The Generator submits plans and specific information to the ESA for inspection. Step 3.1.5 runs in parallel with Step 3.1.6.

3.1.6 GBE Review of Application

3.1.6.1 For Generator at Existing Customer Connection

- Typical requirement is a new meter.
- GBE will check if a service upgrade is required based on Generator supplied information.
- GBE will check if there are any issues associated with a significant amount of generation already on the supply feeder.
- GBE will inform the Generator of any requirements specific to the connection (typically requirements for metering), costs and timing to implement.
- GBE will not charge for preparation of the Offer to Connect.

3.1.6.2 For Generator Not at Existing Customer Connection

A Customer Connection must first be established before an agreement can be made for connection of generation to GBE's system. This new connection process can be done at the same time as the proposed generation connection process, but the time lines will likely be extended since more work may be required.

3.1.7 Decision to Proceed

If the Generator decides to proceed, the Generator will:

- Commit to paying GBE for connection assets (including metering);
- Complete, sign and return the Micro-Distributed Generation Facility Connection Agreement (Appendix 2) to GBE;
- Complete, sign and return the New Generation Account Application Form (Appendix 3) to GBE;
- Begin to install the generation;
- Work closely with GBE and the ESA and any other organizations from which work, inspections, approvals or licenses are required to prevent delays;
- Plan activities in coordination with project milestones and initiate actions at required times; and
- Apply for electrical inspection with the ESA.
- For Net Metering projects, install a disconnect switch between generator and the service panel within 2.0m of the exterior meter base location.

3.1.8 Final Connection

The Generator will contact GBE after completing the ESA inspection process and receiving an Authorization to Connect. GBE will respond within 5 business days to make any necessary metering changes and connect the Generator's Micro-Distributed generation facility to GBE's distribution system. GBE will check to ensure that all Generator commitments have been satisfied (i.e. ESA Authorization to Connect, Signed Connection Agreement, receipt of any required payment, etc.) prior to final connection.

3.2 GENERATION > 12kW

Generation greater than 12kW is classified into three categories as follows:

Small: <= 500kW connected on distribution system voltage < 15kV
 <= 1MW connected on distribution system voltage >=15kV

Mid-Sized: <= 10MW but > 500kW connected on distribution system voltage < 15kV
 > 1MW but <= 10MW connected on distribution system voltage >= 15kV

Large: > 10MW

The connection process is as follows:

3.2.1 Initial Contact

The Generator proposing the installation of a generation facility contacts GBE and the ESA. The transmitter (Hydro One) may need to become involved. The Generator must contact the OEB regarding license applications. For all projects over 10MW, the IESO must be involved to complete a system impact assessment.

3.2.2 Provision of Information

GBE provides a copy of this document to the Generator to outline the connection process, required approvals, technical requirements (including metering), contractual requirements (Connection Agreement), application form and the potential involvement of the transmitter (Hydro One), the IESO and the OEB.

The ESA is responsible for provision of information on electrical safety requirements and its plan approval process.

3.2.3 Development of Generation Plan

The Generator reviews the relevant information from GBE and the ESA and puts together an installation plan. The Generator should follow Section 5 for Net Metering Program. Net Metering project over 12 kW require Connection Impact Assessment.

3.2.4 Initial Consultation (No Charge)

The Generator requests a preliminary meeting and submits the Preliminary Meeting Application Form (Appendix 4), including the following information:

- The name-plate rated capacity of each unit of the proposed generation facility and the total name-plate rated capacity of the proposed generation facility at the connection point;
- The fuel type of the proposed generation facility;
- The type of technology to be used; and
- The location(s) of the proposed generation facility including address and account number with GBE where available.

Within 15 business days of receipt of the Preliminary Meeting Application Form, GBE will set up a meeting (via phone/email/in person) with the Generator to review the plans at a basic level including:

- Location of existing distribution facilities in reference to proposed generation facility;

- The GBE distribution system technical information required to be provided by sections 6.2.9.1 and 6.2.9.3 of the Distribution System code, if this has been requested by the Generator
- Rough estimate on time and costs which could be associated with the project; and
- Basic feasibility of the project.

3.2.5 Application for Connection Impact Assessment

The Generator applies for a CIA by completing and submitting the Connection Impact Assessment Application Form (Appendix 5) and makes payment with the application. A CIA will also be required from Hydro One if the Generator is connected to a part of GBE's distribution system that is fed from a Hydro One Transformer Station. Projects greater than 10MW will require a System Impact Assessment (SIA) by the IESO. GBE will collect payment from the Generator and forward all necessary payments and applicable information on behalf of the Generator to Hydro One and the IESO as required.

Please note that all technical submissions associated with the CIA Application Form, including the form itself, must be signed and sealed by a licensed Ontario Professional Engineer (P.Eng).

3.2.6 Connection Impact Assessment

GBE performs a connection impact assessment of the proposed generation on the distribution system and customers considering:

- Voltage impacts;
- Current loading;
- Fault currents; and
- Connection feasibility and identification of lines/equipment upgrades required, distribution or transmission system protection modifications, and metering requirements.

Where necessary, GBE receives an impact assessment from Hydro One and the IESO.

For Small generation, an Offer to Connect will be made at the end of the impact assessment. For Mid-Sized generation, an overview of cost implications will be made at the end of the impact assessment. For Large generation, all costing will be addressed at a later step.

3.2.6.1 Timing

The time to review and inform the Generator about the results of the impact assessment is as follows from the date of receipt of payment and application:

- Small: up to 60 calendar days where no distribution system reinforcement or expansion is required to facilitate generator connection, up to 90 calendar days where a distribution system reinforcement or expansion is required to facilitate generator connection
- Mid-Sized: up to 60 calendar days
- Large: up to 90 calendar days

3.2.7 Decision to Proceed

If the Generator decides to revise the original plans based on results of the impact assessment, the plans must be re-submitted for another review by going back to Step 3.2.5. Any change in design, equipment or plans requires notification to the ESA.

3.2.7.1 Small

If the Generator is satisfied and decides to proceed:

- Both parties sign a CCA;
- Generator commits to payments;
- Both parties commit to schedules, information exchange, scope of work of the Generator and of GBE;
- GBE initiates the work to be done to facilitate the connection;
- Generator initiates the required activities; and
- Generator must work closely with GBE, the ESA, the IESO (if applicable) and any other organizations from which work, inspections, approvals or licenses are required to prevent delays.

3.2.7.2 Mid-Sized and Large

If the Generator feels that the results of the CIA are manageable, the Generator will request a meeting to develop a scope so that GBE can prepare an estimate and an Offer to Connect.

If the Generator decides to proceed:

- both parties agree to, and sign, scope of project; and
- Generator pays for preparation of estimate by GBE, Hydro One (if applicable), and IESO (if applicable).

GBE will notify Hydro One and the IESO as required within 10 business days of receiving payment and notification that the Generator has decided to proceed and that an estimate is to be prepared.

GBE will prepare a detailed estimate of the project based on the agreed upon scope.

GBE will prepare its Offer to Connect within 90 calendar days of receipt of payment from the Generator. In any event, GBE has up to 30 calendar days from date of receipt of comments from Hydro One and/or the IESO to incorporate them into the estimate.

If the Generator decides to proceed after reviewing the Offer to Connect:

- All parties agree to, and sign, a CCA
- Generator agrees to payment schedule for work required by GBE and/or Hydro One and/ or the IESO;
- All parties commit to schedules, information exchange, scope of work; and
- The generator must work closely with GBE, the ESA, the IESO (if applicable) and any other organizations from which work, inspections, approvals or licenses are required to prevent delays.

3.2.8 Implementation

Both parties commit to obtain required approvals:

- Generator prepares detailed engineering drawings;
- Generator submits all detailed plans to ESA for Plan Approval process (includes detailed single line diagram and interface protection); and
- Generator submits the following information to GBE for design review (three copies certified by a licensed Ontario Professional Engineer (P.Eng.)):
 - Project Summary containing:
 - site location
 - prime mover type (internal combustion engine, gas turbine etc.)
 - anticipated generator output (including any seasonal and daily variations)
 - proposed installation schedule
 - future expansion plans (if applicable)
 - Single line electrical diagrams containing:
 - generator connections
 - voltage levels
 - transformer connections
 - isolating devices
 - fusing
 - protective relaying
 - metering
 - Nameplate data on:
 - protective relays (including descriptive bulletins)
 - synchronizing devices (including descriptive bulletins)
 - load interrupter switches (including reactance levels)
 - generator(s) (including reactance levels)
 - transformer(s) (including reactance levels)
 - circuit breakers (including descriptive bulletins)

- Protection system design and operating procedures.
- AC and DC protection schematics.
- Fault calculations, protective relay settings, fuse selection and coordination study.
- Station service and battery system details.
- Grounding studies and results.
- Commissioning procedures and schedule.
- Operating procedures.
- Maintenance procedure and record keeping.

It is recommended that this information be provided within 30 days of signing the CCA to allow for a timely design review.

GBE performs design review to ensure that the detailed engineering is acceptable. It is recommended that this review be complete before equipment purchase by the Generator. GBE will not be held liable for any costs incurred for equipment or services ordered before the design review is complete.

The Generator receives the design review from GBE. The Generator can then order equipment, begin construction, obtain ESA approvals, etc. GBE can begin connection work and complete any necessary line/equipment upgrades.

The Generator completes construction and applies for ESA electrical inspection for an Authorization to Connect (necessary for connection by GBE).

3.2.9 New Account Application, Sales Tax Form, and Connection Agreement

If the Generator is not applying under the Net Metering Program then they must complete and submit a New Generation Account Application Form (Appendix 3) at least 30 days prior to the proposed date of connection.

The Generator and GBE agree to, and sign, the Connection Agreement. If necessary, GBE and Hydro One will review existing agreements for required revisions.

The form of the Connection Agreement is contained in Appendix E of the OEB Distribution System Code.

A temporary Connection Agreement for the purpose of connection for commissioning and verification may be signed at this point while negotiating the final Connection Agreement.

3.2.10 Commissioning and Verification

The Generator arranges for commissioning and testing of the facility. GBE witnesses and verifies the commissioning process. Hydro One witnesses and verifies the commissioning process as required. A final Connection Agreement is signed if a temporary one was used for commissioning and verification.

3.2.11 Completion

If everything is satisfactory, the generation facility is fully connected and operational. The Generator must ensure that all GrandBridge Energy obligations are met if participating in the Net Metering Program in order to ensure excess generation credits are accumulated in a correct manner.

4 GENERAL TECHNICAL REQUIREMENTS

The Generator shall ensure that the connection of its generation facility to the distribution system does not materially adversely affect the safety, reliability and efficiency of GBE's distribution system. Generation facilities must meet the technical requirements specified in the OEB's Distribution System Code, Appendix F.2 of the OEB's Distribution System Code and the requirements of Energy+.

Generation facilities will vary significantly in size, complexity and details. The following sections describe some general technical requirements that may or may not apply to a specific installation. Specific technical requirements will be provided to each applicant for new generation based on the specifics of the project.

4.1 CONNECTION POINT

4.1.1 Interconnection Switch

Three-phase, gang-operated, lockable, visible opening load interrupting switch(es) with provision for grounding shall be installed at the interface point between the GBE distribution system and the Generator's Facilities, including the metering. The use of the switch(es) will be to isolate the DG in case of emergency and for work protection. The switch(es) shall be provided, installed and maintained by the Generator unless other arrangements are made and approved by GBE. GBE will have operating control of the interconnection switch(es).

4.1.2 GBE Access

Immediate access to the interconnection switch(es) as well as the rest of the Generator's Facilities where other operating devices, relays, control switches, metering equipment, etc. associated with the DG may be located must be provided on a 24 hour, 7 days a week basis for GrandBridge Energy personnel or its agents.

4.1.3 Fault Interrupting Devices

Suitable three-phase fault interrupting devices (circuit breakers acceptable to GBE) shall be provided to immediately interrupt and isolate faults in the utility or faults in the Generator's Facilities and handle other abnormal conditions such as "islanding".

4.1.4 Generation Connection Point

A generating unit may be connected to the Generator's existing electrical system. The generation connection point is often not at the service entrance, but downstream at one of the Generator's switchboards. In the latter case, an alternate type of load break switch may be acceptable to GBE. The generator connection switch must still meet functional requirements outlined above and pass ESA inspection. A mechanical interlock between the generator connection switch and the generator breaker will be required. The generator connection switch must have visible isolation.

4.1.5 Point Of Isolation

For the work protection of GBE crews, a point of isolation is *always* required to isolate the DG. A local disconnect must be installed between the generation meter and the generator and must be located within 2.0m of the load meter.

4.1.6 Supervisory Control

Supervisory control may be required for the control and monitoring of the load interrupting switches and circuit breakers, annunciation of the interface protection failure and telemetry of generator power outputs. If GBE determines supervisory control is required, the Generator will be required to cover all costs associated with the installation of a Generator owned RTU (Remote Terminal Unit) and associated hardware compatible with the GBE Control Centre SCADA system and initial and ongoing communication costs. If the capacity of a generator is less than or equal to 500 kW, SCADA and PQ monitoring are not required.

4.2 VOLTAGE

4.2.1 Primary Distribution Voltage Level

GBE primary distribution voltages are 4.16 kV, 8.32kV and 27.6 kV depending on the geographical area. The distribution circuits are effectively grounded for 4-wire distribution (phase to neutral connected loads).

There are size limitations with respect to connecting DGs to 27.6kV underground residential distribution systems that primarily supply residential and low-density commercial areas.

No "Mid-Size" or "Large" generation connections may be made on the 4.16 kV or 8.32kV system since this system is being converted to 27.6 kV. "Small" connections to

the 4.16kV or 8.32kV system will be considered on an individual basis. "Micro" connections are acceptable on the 4.16kV, 8.32kV and 27.6kV systems.

4.2.2 Interface Transformer

An interface transformer will be required to transform the Generator's system voltage to a higher voltage suitable to connect to an GBE distribution 27.6 kV distribution circuit. The interface transformer shall be grounded wye primary and grounded wye secondary for connection to GBE's four wire distribution system if a DG size is less than 1 MW. However, an interface transformer with another configuration may be required for DG connection if a DG size is greater than 1 MW. The possible configurations are:

- a) Wye-Ground : delta;
- b) Wye-Ground : wye-Ground with a Delta tertiary;
- c) Wye-Ground:wye-Ground (LV may be ungrounded) with a HV Grounding Transformer; or
- d) Delta-wye with HV Grounding Transformer;

An interface transformer can be an existing transformer for load or a dedicated transformer. If a dedicated transformer is installed and the generation meter is on the secondary side of the transformer, 1% transformer losses will be deducted from the generated kWh.

The configuration of an interface transformer shall be determined in the CIA.

4.2.3 Voltage Regulation

Adequate voltage regulation shall be maintained under a variety of operating conditions. An off-load tapchanger is normally used for voltage matching. The loading/unloading rate of the generator, the starting current of induction generator and auxiliary motors should be regulated to protect the GBE distribution system from voltage swings. Where necessary, system power flow studies must be submitted to GBE to confirm voltage regulation requirements.

4.3 PROTECTION SYSTEM

4.3.1 Protection System Goals

Protective relaying must be designed to provide maximum safety and reliability. The Generator's protective relaying shall co-ordinate with the existing GBE protective devices (and Hydro One's, where applicable). The protective system shall be capable of automatically isolating the EG from the GBE distribution system in the following situations:

- Internal faults within the generator.
- Faults occurring in the Generator owned switchgear.

- External faults in the GBE distribution system.
- Certain abnormal system conditions (such as over/under voltage, over/under frequency) that could result in “islanding”.

To meet protection system goals, the Generator must provide adequate protective relaying for interface protection between the GBE distribution system and the Generator’s Facilities. Routine verification shall be required to ensure that the protections will respond to various fault conditions.

Protective equipment specified by GBE is for the protection of the GBE distribution system (and Hydro One equipment, if applicable) only. Additional protection will be required for the generation system.

The Generator should be aware that certain conditions in the utility system may affect the generator. It is the sole responsibility of the Generator to protect the equipment from conditions on the utility system.

Where modifications to existing distribution protection systems are required (and permitted), the Generator shall be responsible for all associated costs unless the Generator is a renewable energy generation facility, where some or all of these costs may be covered by GBE.

4.3.2 Interface Protection Requirements

Interface protection shall be provided to detect any faults in the GBE distribution system and any abnormal conditions in the Generator’s system and to trip the generator/interface breaker to isolate the generator from the GBE distribution system.

The interface protection shall include:

4.3.2.1 Ground Fault Protection

Ground overcurrent relay (50N & 51N), or distance relay (21N) is required to detect ground faults.

4.3.2.2 Phase Fault Protection

To detect phase faults, one or more of the following protective relays must be installed by the Generator:

- Distance relay (21), phase to phase
- Phase directional overcurrent relay (67)
- Voltage-restrained overcurrent relay (51V)
- Overcurrent relay (51)

4.3.2.3 Protection for Islanding/Abnormal conditions

Voltage, frequency and reverse power protective relays are required to separate the DG from the GBE distribution system in an islanding condition. This is when the utility breaker is opened and the generator is still connected to the GBE distribution system.

- Overvoltage relay (59 or 59I)
- Undervoltage relay (27)
- Overfrequency (81O)
- Underfrequency (81U)
- Reverse power relay (32)

4.3.3 Relay Types and Settings

All the utility-generator interface protective relays shall be utility grade (not industrial grade). The types and settings of the protective relays shall be approved by GBE. The relays shall be equipped with self-checking features. A dedicated locked cabinet, panel with locked cover or sealable relay covers shall be provided to ensure the relay settings are not tampered with or adjusted without GBE's approval. A backup protection scheme may be required. A separate DC supply to the protective relays is required.

4.3.4 Fault Levels and Protection Coordination

GBE will provide present three-phase fault levels which are always subject to change. Typical maximum available three-phase faults are 800 MVA for 27.6 kV systems. A protection co-ordination study will be required for all installations. All installations may be supplied from more than one GBE feeder (at various times). These feeders may have different fault levels and originate from different transformer stations or transformers within the same transformer station. The protection scheme and protection co-ordination will not account for these possibilities and thus the Generator will only be allowed to connect on feeders on which the study has been completed for.

The additional fault current contribution from the generator will result in an increase in fault level that may have an impact on the GBE distribution system. GBE may require the Generator to limit the generator fault current contribution to protect GBE equipment (i.e. breaker, switches) if the fault current is expected to be greater than design limits.

4.3.5 Generator/Interface Circuit Breaker

An automatic circuit interrupting device (usually a circuit breaker within switchgear) initiated by protective relays shall be provided by the Generator for generator/interface protection. The device must have adequate fault current interrupting capability.

4.3.6 Synchronizing

Synchronizing check shall be provided for the interface and generator breakers of the generation system that can produce electrical energy without being connected to the GBE distribution system. All breakers and devices (i.e. switches) between the generator and the GBE distribution system shall be interlocked with the synchronizing breakers.

4.3.7 GBE Breaker Reclosing Scheme

Most short circuits on overhead feeders are temporary. The GBE distribution system incorporates an automatic reclosing scheme to reclose the circuit breakers on such feeders typically within less than a half second after they have been automatically tripped by the feeder protections. This improves continuity of service to all customers.

The Generator must provide a reliable means of disconnecting the DG from the distribution system prior to the feeder breaker reclosing. GBE is not liable for the damage to the Generator’s generation facility due to the reclosure of a feeder breaker.

The Generator must disconnect the DG from the GBE distribution system when system power is lost or when an electrical fault occurs, and remain disconnected.

4.3.8 Transfer Trip Protection Requirement

Depending on the generation system connected to the feeder and the minimum feeder load, a Transfer Trip (TT) facility between the transformer station and the Generator’s Facilities will be considered. If the generation system can operate successfully in an islanded mode (i.e. maintain normal voltage and frequency) then the transfer trip must be provided to isolate the generation system of the Generator’s Facilities.

If the generation system connected to the feeder is less than 50% of the minimum feeder loading and aggregate capacity is less than 1 MW, a TT trip is generally not required. However, the Generator is required to provide redundant islanding protection timed to ensure that the interface breaker is tripped prior to the feeder breaker reclosing. The TT protection may be required if the auto reclose time on the feeder breaker is less than the anticipated generator protection system fault clearing time. TT communications shall meet the timing requirements in Table 1. The

Maximum TT time shall depend on the speed of the DG Facilities interrupting device

Maximum TT Time (ms)	Speed of DG Facilities Interrupting Device (cycles)
83	3
67	4
50	5
33	6
17	7

Table 1: TT Timing Requirements

The DG protection must be designed by considering the following conditions

- The DG Facility shall remain disconnected from GBE's Distribution System if the TT channel is unavailable.
- The TT teleprotection system shall be failsafe.
- Upon loss of the TT communication channel, the DG and HV ground sources shall disconnect within 5 seconds of the channel failing. A controlled shutdown may be allowed and must be submitted to GBE for approval.
- The DG Facility shall remain disconnected until the TT channel is repaired and the controlling authority has been advised that all DG Facility interconnection protections have been restored to service.

A ground potential rise study may be required at the Generator's Facilities for the installation of telephone wires as the communication channel(s) between the transformer station and the Generator's Facilities. The study is to ensure the new electrical facilities do not present a safety hazard or adversely affect telecom and protection facilities. The Generator shall assure that the need for ground potential rise study is reviewed.

4.3.9 Protection System Failure

If at any time the protection system, including transfer trip protection when installed, is not functioning or out of service or the DC supply is lost, the generator/interface breaker must be opened to isolate the generator from the GrandBridge Energy distribution system. This breaker must remain open until the protection system is returned to service.

4.4 TYPE OF GENERATION

Depending upon the type of generation, the following additional design criteria will be required.

4.4.1 Induction Generator

The induction generator requires a source of external excitation before the machine can produce any power. As a result, the chance of external islanding is remote. The protection and control systems for this type of machine can be somewhat simpler than those required for a synchronous machine. It is, however, essential to have a reverse-power relay to ensure that the machine cannot operate as a motor.

Induction generators, by the nature of their design, run at lagging power factor. GrandBridge Energy requires the overall power factor to be equal to or greater than 0.9 lagging. As a result, suitable power-factor correction capacitor banks are recommended, and will likely be required on generation over 200kVA capacity. If capacitors are used, they must automatically be isolated whenever the generator breaker is open and must be sized carefully to avoid the risk of self-excitation of the generator. The self-excited induction generator can produce abnormally high voltages that can cause damage to the equipment of other GBE Generator customers.

The Generator shall furnish generator starting data to GBE for review. System power flow studies may be required to evaluate the impact of generator starting to voltage regulation.

4.4.2 Synchronous Generator

Since the synchronous generator can produce electrical energy without being connected to the GBE distribution system, a more advanced protection and control system is required. The control system shall be provided with equipment necessary to establish a synchronous condition. In the event of a utility outage of even momentary duration, an automatic synchronization device shall prevent reconnection of the generator to the utility system until synchronism is re-established.

Synchronous generators can produce power at both leading and lagging power factors. The production of power at an excessive leading power factor can cause over-voltages in the distribution system. The generator can be run at leading power factor to offset lagging loads in the Generator's Facilities, however, overall plant power factor must remain between 0.9 lagging and unity.

4.4.3 Inverter Type Generator

Utility-interactive inverters do not require separate synchronizing equipment. Non-utility-interactive or stand-alone inverters shall not be used for distributed generation with the GBE distribution system.

An inverter type generator connected to the GBE distribution system shall operate with the power factor between 0.9 lagging and unity.

The utility-interactive inverters must include filters to minimize the harmonic output (see section 4.5) so as not to disturb the GBE distribution system or other customers in any way.

Generators with less than 100kW total capacity, such as micro-turbine generators without black start capability, may automatically restart following automatic reclosing of the feeder breaker. Generators that automatically restart must have an adjustable time delay on restart up to 5 minutes. GBE will co-ordinate the settings of generator restart time-delays such that generators on any feeders do not restart all at once to avoid voltage flicker.

4.5 POWER QUALITY

4.5.1 Design Goals

Negative effects on power quality must be prevented. These include: objectionable harmonics, voltage distortion, voltage flicker or poor power factor on the GBE distribution system or on other customers' electrical and communication systems.

4.5.2 Power Quality Requirements

The Generator's Facilities shall meet the guidelines set out in the CSA C22.3 No.9-08 (latest edition) titled "Interconnection of distributed resources and electricity supply systems".

The current Total Demand Distortion (TDD) shall not exceed 5% of the fundamental frequency (60Hz) when measured on the distribution system side of the interconnection switch. The individual harmonic limitation is shown in Table 1 of C22.3 No.9-08.

4.5.3 Future Requirements

If at any time before or after the in-service date, additional filters, other equipment, or modifications are needed to meet these specifications or future specifications, the Generator shall take the necessary steps to meet GBE's requirements. The Generator shall pay all costs associated with modifications deemed necessary by GBE to achieve acceptable power quality or the generator must be disconnected from the GBE distribution system.

4.5.4 Phase Unbalance

Unbalances in phase current and phase voltage can occur on GBE's four wire distribution system. Specific unbalancing varies by feeder. The DG connected to the distribution system must be capable of operating under these conditions and shall not make worse the existing unbalanced conditions.

4.5.5 Frequency

The generator shall be operated within the range 59.3Hz to 60.5Hz. 60 hertz is the normal electrical system frequency.

4.5.6 Voltage Flicker

Voltage flicker is described as an increase or decrease in voltage over a short period of time, normally associated with fluctuating load. The characteristics of a particular flicker will depend on the characteristics of the corresponding load (percentage voltage dip, frequency of occurrence). This type of problem may arise during the start-up of an induction generator as the large starting current may cause the voltage to dip considerably. The Generator must take steps to minimize flicker problems to the acceptable level.

4.5.7 Power Factor

When the actual Generator load approaches the output level of the generator, the net power factor may be adversely affected. The Generator shall ensure that the net generator/load power factor remains between 0.9 lagging and unity.

4.6 METERING

4.6.1 Metering Requirements

Metering requirements are to be determined by GBE and dependent on the type and size of generator and the total demand of the Generator's Facilities. The installation of these meters may require additional metering cabinets, metering cells, a dedicated 120 Volt AC supply to each meter cabinet and possibly a telephone connection. The Generator shall be required to cover the costs of additional equipment and monthly telephone charges, if applicable. GBE shall own, and have safe access to all metering equipment, including instrument transformers at all metering locations.

The Generator will also be required to comply with all the metering requirements specified in GBE's Conditions of Service and GBE's Metering Specifications (both as amended from time to time). Depending upon the size of the generator, the Generator may also be required to install IESO compliant metering equipment for gross load billing purposes.

The generation meter must be located within sight and within 2.0m of the existing load meter. The only exception to this rule would be if placing the meter somewhere else would be technically or economically advantageous to GBE and will be determined on a case-by-case basis.

Where the Generator will be exporting power onto the distribution system, a bi-directional meter with four-quadrant interval measurement capability will be required.

Where export of power is not required, such as back-up capability or generation for non-exporting but not including Net Metering program, the metering requirement will be the same manner as other load customers. A reverse power relay shall also be installed to ensure blocking of any power exports.

Should the Generator receive pulses or data from regular GBE metering for monitoring or load management purposes, and the meter fails to deliver the data due to failure or breakdown, GBE will not be responsible for any damage to or additional operational requirements of the Generator's Facilities.

At some locations, additional metering required for the generator may introduce a need for multiple telephone circuits, or circuits in addition to those already present. It will be the Generator's obligation to provide, operate and maintain additional phone lines, or approved line sharing or call managing equipment.

4.6.2 Metering Instrument Transformers

The point of connecting metering instrument transformers is critical and must be approved by GBE.

GBE will not share any metering instrument transformer circuits for non-revenue metering applications or any other purposes. All metering equipment that is part of the instrument transformer circuits must have Measurement Canada approval for billing and be inspected in accordance with Measurement Canada regulations.

For a customer owned 27.6kV substation, the Generator must include an GBE revenue metering cell.

4.7 SYSTEM CHANGE

If at any time the Generator proposes changes, modifications or additions to the Generator's Facilities or protection and control system including relay settings, the Generator must give GBE the opportunity to review and approve of these modifications before they are implemented. The Generator shall not arbitrarily or unilaterally implement any changes, modifications or additions to the Generator's Facilities. Where changes require re-testing or commissioning, GBE reserves the right to witness such testing. Reasonable notice shall be provided to GBE.

4.8 SYSTEM DOCUMENTATION

Documentation on the Generator's Facilities, as built, shall be provided to GBE before the in-service date. This documentation shall include a detailed single line diagram, AC and DC elementary, relay types, protection co-ordination studies and setting sheets.

4.9 WARNING NOTICES AND DIAGRAMS

In addition to ESA requirements, the following notices shall be provided:

A warning notice indicating the presence of a distributed generation system shall be installed, prior to commissioning. The following sign shall be posted at the door of the switch room and the door of the generator room, one sign per door at the Generator's Facilities.

**CAUTION
DISTRIBUTED GENERATION**

A single line, permanent and legible diagram of the switching arrangement, shall also be placed at the Generator's control room and the switch room to indicate the position of the DG(s) and isolation points with their interlocking arrangements.

Operating designations will be assigned to the switching equipment of the generation system as required by GBE. The Generator shall update single line electrical diagram and operating diagram to include the assigned operating designations, and the switching equipment shall be identified by the operating designations as well.

4.10 VERIFICATION OF PROTECTION SYSTEM

Routine verification of the utility-generator interface protective relays and protective devices shall be performed on a scheduled basis. Testing intervals for protection systems should not exceed four (4) years for microprocessor-based systems and two (2) years for electro-mechanical based systems.

Test switches shall be provided to isolate current and potential transformer input to the relays as well as a set of switches to isolate the relays tripping outputs from the generation system control circuitry.

The Generator shall make available to GBE records of relay calibration and protection verifications so that records of the interface protective relays can be maintained. The specific records shall be identified in the Connection Agreement.

4.11 INSPECTION REQUIREMENTS

The Generator shall allow GBE and/or its agent(s) free and unrestricted access to the Generator's Facilities for inspection and safety checks, given reasonable notice. The Generator shall demonstrate the correct operation of the generation system including the protection and control equipment as may be required by GBE.

4.12 PERFORMANCE UNDER THIS SPECIFICATION

1. If at any time the Generator fails to perform any obligation under this Agreement or any other written requirements of GBE, GBE may give notice to the Generator or the Generator's designate, as documented in the Operations Schedule, which notice may be given by telephone, to immediately remedy the failure. In all cases, GBE will attempt to give the Generator notice and ample time to remedy any problems and comply with this specification, however, GBE will always have the right to immediately disconnect the DG without any notice.
2. GBE may require the disconnection of the generation system, or discontinue the supply of electricity to the Generator for any good and substantial cause in the opinion of GBE, acting reasonably, including but not limited to the following reasons:
 - (a) for safety of persons, plant, or equipment;
 - (b) to perform planned or unplanned maintenance on GBE equipment;
 - (c) when work protection is required on the GBE distribution system or the Generator's Facilities;
 - (d) when the GBE distribution system is in an abnormal or emergency operating condition;
 - (e) when the Generator's Facilities are operating abnormally or are adversely affecting the GBE distribution system by way of frequency and voltage fluctuations; and

- (f) when Hydro One load shedding is required.

GBE will give the Generator as much notice as possible before disconnecting the supply of electricity; however, GBE will always have the right to immediately disconnect the DG without any notice.

3. Neither party shall be held responsible or liable for any loss, damage, detention, delay, failure or inability to meet any of its obligations specified in this requirements or any documents referred to herein because of events beyond its reasonable control, including without limitation, acts of God, acts of a public enemy, war, hostilities, invasion, insurrection, riot, the order of any civil or military government, explosion, fire, strikes, lockouts, labour disputes, malicious acts, vandalism, failure of equipment, accident to the Generator's Facilities or the GBE distribution system (or the Hydro One system, if applicable), storms or other adverse weather conditions or other causes of a similar nature.

4.13 LIABILITY

As part of installing and operating the Generator's Facilities, the Generator shall:

1. Assume all risk, liability or obligation in respect to all loss, damage or injury to:
 - (a) property of the Generator, property of GBE and Hydro One, if applicable, or property of any third party on the lands and premises on the Generator's side of the Delivery Point. The Delivery Point is defined as GBE's disconnection device on the distribution line connecting the Generator's Facilities to GBE's distribution system as identified in the Operations Schedule.
 - (b) any person or persons (including loss of life) on the said lands and premises on the Generator's side of the Delivery Point, which loss, damage or injury was due to power supplied by GBE to the Generator to the extent used to supply power to the Generator, except to the degree that such loss, damage injury was due to the negligence of GBE, its servants or agents. Without limiting the generality of the foregoing, the Generator shall be responsible, except to the degree that such is caused by the negligence of GBE, for the cost of any damage to the Generator's equipment and transformers or any damage to equipment of a third party that may occur due to the operation of the Generator's Facilities or of GBE's distribution system.
 - (c) all actions, causes of action, suits, proceedings, claims, demands, losses, damages, penalties, fines, costs, expenses, obligations and liabilities arising out of a discharge of any contaminant into the natural environment on the Generator's lands and premises and any fines or

orders of any kind that may be levied or made pursuant to the Environmental Protection Act (Ontario), the Ontario Water Resources Act, or the Dangerous Goods Transportation Act (Ontario), or other legislation or legal requirements whether federal, provincial or municipal, except to the degree that such discharge was due to the negligence of GBE, its servants or agents.

2. Indemnify GBE, and Hydro One, and save each harmless from all risk, liability, and obligation assumed by the Generator and all claims and demands in connection therewith, save and except such loss, damage or injury due to the negligence of GBE, Hydro One, or their respective servants or agents.
3. Assume all risk for the existence of all distribution lines, plant, meters and equipment of GBE on or in the lands and premises on the Generator's side of the Delivery Point. If any of this equipment is destroyed or damaged other than by ordinary wear and tear or due to the fault of GBE or defect to the equipment, the Generator shall pay to GBE the cost of repairing or replacing this equipment as determined by GBE.
4. The Generator shall add GBE onto their liability insurance policy as an additional insured. A Certificate of Insurance shall be provided to GBE by the Generator evidencing this fact prior to the in-service date of the generator and this Certificate of Insurance shall be appropriately filed with GBE and renewed each year thereafter. The Generator's liability policy shall have a minimum limit of insurance of \$10 million per occurrence.

5 NET METERING

As a way to encourage conservation, GBE welcomes eligible customers wishing to participate in the Ontario Ministry of Energy's Net Metering program.

5.1 What is Net Metering?

Ontario's net metering regulation allows you to send electricity generated from renewable sources to the electrical grid for a credit toward your energy costs. GBE will subtract the value of electricity you supply to the grid from the value of what you take from the grid. What you'll see on your bill is the "net" difference between those two amounts. If you supply power that is worth more than what you take from the grid over the billing period, you'll receive a credit that can help lower future energy bills. The more electricity you produce, the greater your savings.

5.2 How will your hydro bill be calculated?

GBE will continue to read your meter just as we do now. The bill you see will reflect the value of the energy you exported to the grid at time-of-use (TOU) rates and the

value of the energy you needed to take from the grid at TOU rates. All of the regulated charges apply only to your net consumption - if that portion of your bill is zero, or a credit, your bill will include only GBE's fixed monthly access charge. If you have more credit than you can apply to one bill you can carry the balance forward for up to one year to offset future costs. To cancel a net metering agreement, all you need to do is provide GBE with 90 days written notice.

5.3 Who is eligible?

Net metering is available from GBE to any customer who generates electricity primarily for their own use from a renewable source (wind, water, solar or agricultural biomass) and meet GBE technical, safety and inspection requirements.

5.4 How do you get started?

In order to participate, you must meet all the requirements for distributed generation as outlined in this document for the proposed size of generation. You may also want to contact the ESA at 1-877-ESA-SAFE (1-877--372-7233) or on-line at www.esainspection.net. The ESA must inspect and approve your system. The Ontario Ministry of Energy has published a booklet entitled "Net Metering in Ontario" which is a useful guide. The Ministry of Energy can be reached at 1-888-668-4636 or on-line at www.energy.gov.on.ca.

6 IESO FEED IN TARIFF PROGRAMS

The IESO's Feed in Tariff and micro Feed in Tariff programs have been discontinued and are no longer available. Any projects that had a contract with the IESO under these programs will still be under contract with the IESO as per the FIT/microFIT rules.



Appendix 1

Micro-Distributed Generation Application Form (DG≤12 kW)

Applicant Information

Company/Owner Name: _____

Contact Name: _____

Mailing Address: _____

Phone Number: _____

E-Mail Address: _____

Existing Customer: Yes No

If yes, Account Number: _____

Proposed Generation Location Information

Site Address: _____

City/Town/Township: _____

Lot Number: _____

Concession Number: _____

Applicant's Ownership Interest in the Generation System

Owner Co-Owner Lease Other

Program Type

Non-Exporting Net Metering
 Other: _____

Project Information

Proposed In-Service Date (mm/dd/yy): _____

Incremental Project: Yes No

If yes, Existing Generation Nameplate Capacity (kW AC rating): _____

Proposed Total Generation Nameplate Capacity (kW AC rating): _____

Generation Connection Type: Single Phase Three Phase

Fuel Type:

Wind Water Biomass Bio-gas Landfill Gas
 Solar (Rooftop) Solar (Ground Mounted) Other: _____



Appendix 1

Manufacture (PV panel): _____

Model Number (PV panel): _____

Number of PV panels: _____

Generator/Inverter Information

Number of Phases: Single Phase Three Phase

Type: Synchronous Induction Inverter

Inverter Certification: C22.2 #107.1 UL 1741 Site Certified by the ESA

Nameplate Rating (kW AC rating): _____ Output Voltage (V): _____

Manufacturer: _____

Model Number: _____

Metering Connection Setup

Net Metering/Non-exporting

Single line diagram # _____ attached with application

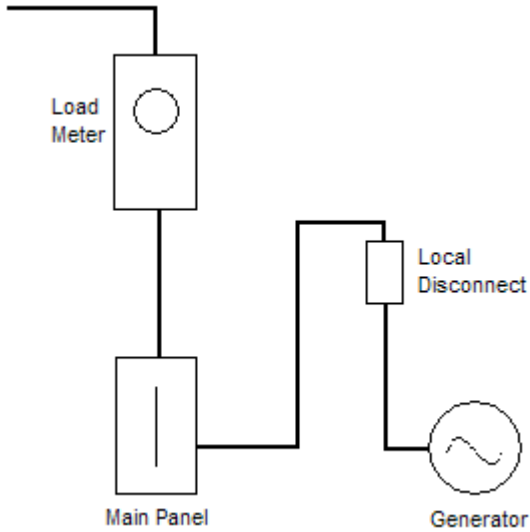

Please Return Completed Application to:

GrandBridge Energy Inc.
Attn: Generation
Email: generation@grandbridgeenergy.com



Appendix 2

Micro-Distributed Generation Facility Connection Agreement

In consideration of GrandBridge Energy Inc. agreeing to allow you to connect your 12kW name-plate rated capacity or smaller generation facility to GrandBridge Energy's distribution system, you hereby agree to the following terms and conditions.

1.0 Eligibility

1.1 You agree that your generation connection shall be subject to all applicable laws and bound by the terms and conditions of GrandBridge Energy's Conditions of Service, which have been filed with the OEB and are available on request.

2.0 Technical Requirements

2.1 You represent and warrant that you have installed or will install prior to the connection of your generation facility to GrandBridge Energy's distribution system, an isolation device satisfying Section 84 of the Ontario Electrical Safety Code and agree to GrandBridge Energy's staff operation of this as required for the maintenance and repair of the distribution system.

2.2 You agree to perform regular scheduled maintenance to your generation facility as outlined by the manufacturer in order to assure that connection devices, protection systems, and control systems are maintained in good working order and in compliance with all applicable laws.

2.3 You agree that during a power outage on the GrandBridge Energy system your generation facility will shut down, unless you have installed special transfer and isolating capabilities on your generation facility. You agree to the automatic disconnection of your generation facility from GrandBridge Energy's distribution system, as per the generator protective relay settings set out in this Agreement, in the event of a power outage on GrandBridge Energy's distribution system or any abnormal operation of GrandBridge Energy's distribution system.

2.4 You covenant and agree that the design, installation, maintenance, and operation of your generation facility are conducted in a manner that ensures the safety and security of both the generation facility and GrandBridge Energy's distribution system.

2.5 Due to GrandBridge Energy's obligation to maintain the safety and reliability of its distribution system, you acknowledge and agree that in the event GrandBridge Energy determines that your generation facility (i) causes damage to; and/or (ii) is producing adverse effects affecting other distribution system customers or GrandBridge Energy's



Appendix 2

assets, you will disconnect your generation facility immediately from the distribution system upon direction from GrandBridge Energy and correct the problem at your own expense prior to reconnection.

3.0 Liabilities

3.1 You and GrandBridge Energy will indemnify and save each other harmless for all damages and/or adverse effects resulting from either party's negligence or willful misconduct in the connection and operation of your generation facility or GrandBridge Energy's distribution system.

3.2 GrandBridge Energy and you shall not be liable to each other under any circumstances whatsoever for any loss of profits or revenues, business interruptions losses, loss of contract or loss of goodwill, or for any indirect, consequential, incidental or special damages, including but not limited to punitive or exemplary damages, whether any of the said liability, loss or damages arise in contract, tort or otherwise.

Compensation and Billing

4.1 If you are not an embedded retail generator, you agree that, subject to any applicable law:

- GrandBridge Energy will not pay you for any excess generation that results in a net delivery to GrandBridge Energy between meter reads; and
- there will be no carryover of excess generation from one billing period to the next unless you are, at the relevant time, a net metered generator (as defined in section 6.7.1 of the Distribution System Code).
-

4.2 If you are an embedded retail generator selling output from the distributed generation facility to the Ontario Power Authority under contract, you agree that GrandBridge Energy will pay you for generation in accordance with the Retail Settlement Code.

4.3 If you are an embedded retail generator delivering and selling output to GrandBridge Energy, you agree that GrandBridge Energy will pay you for generation in accordance with the Retail Settlement Code.

4.0 Termination

5.1 You understand that you have the right to terminate this agreement at any time, and that by doing so you are required to disconnect your generation facility and notify GrandBridge Energy of such action.

5.0 Assignment



Appendix 2

6.1 You may assign your rights and obligations under this Agreement with the consent of GrandBridge Energy, which shall not withhold its consent unreasonably. GrandBridge Energy shall have the right to assign its rights and obligations under this Agreement without your consent.

I understand, accept and agree to comply with and be bound by the above terms and conditions governing the connection of my generation facility to GrandBridge Energy's distribution system.

Generator Signature: _____ Date: _____

Print name and LDC account number: _____

I confirm that the following information is true and accurate:

Nameplate rating of Generator: _____ kW Total installed generation _____ kW

Type: Wind Turbine Photovoltaic (Solar) Hydraulic Turbine Fuel Cell
 Other _____

Inverter Utilized: Yes No

Inverter Certification: C22.2 #107.1 UL 1741 Site Certified by the ESA



Appendix 2

Generator Protective Relay Settings

Table 1: Inverter Based Generation

The following relay settings shall be used for inverters built to the CSA standard: Source: CSA C22.2 No. 107.1-01 Table 16

System Voltage Vn = V nominal V (Volts)	Frequency F (Hertz)	Maximum number of cycles to disconnect	
		Seconds	Cycles
$V < 0.5 V_n$	60	0.1	6
$0.5 V_n \leq V < 0.88 V_n$	60	2	120
$1.10 V_n \leq V < 1.37 V_n$	60	2	120
$V > 1.37 V_n$	60	0.033	2
Vn	$F < 59.5^*$	0.1	6
Vn	$F > 60.5$	0.1	6

* The UL1741 & IEEE P1547 Standards use $F < \text{rated} - 0.7$ i.e. 59.3 Hz. To update if CSA C22.2 No.107.1-01 is changed.

Table 2: Non Inverter Generation

GrandBridge Energy's minimum requirements, for other generation are as follows:

System Voltage Vn = V nominal V (Volts)	Frequency F (Hertz)	Maximum clearing time*	
		Seconds	Cycles
$V < 0.5 V_n$	60	0.16	9.6
$0.5 V_n \leq V < 0.88 V_n$	60	2	120
$1.10 V_n \leq V < 1.20 V_n$	60	1	120
$V > 1.20 V_n$	60	0.16	9.6
Vn	$F < 59.3$	0.16	9.6
Vn	$F > 60.5$	0.16	9.6



Appendix 2

*Clearing time is the time between the start of the abnormal condition and the generation ceasing to energize GrandBridge Energy's distribution system.

- If you are uncertain about your generation equipment's protective relay settings, please check with your generating equipment supplier.
- Automatic reconnect setting time for your generator is after 5 minutes of normal voltage and frequency on GrandBridge Energy's distribution system.



Appendix 3

New Generation Account Application Form

Applicant Information

Load Customer Account Number (if applicable): _____

For a residential customer

Title: Mr. Miss Mrs. Ms.

Applicant Legal Name (must be the same as that on your microFIT/FIT application)

Applicant primary contact details

First Name: _____ Last Name: _____

Date of Birth (dd/mm/yyyy) _____

Home Phone Number: _____ Work Phone Number: _____

Employer: _____

Email Address: _____

HST Registrant? No Yes

Second Adult Living at Address Information (if applicable)

Title: Mr. Miss Mrs. Ms.

First Name: _____ Last Name: _____

Date of Birth (dd/mm/yyyy): _____ Work Phone Number: _____

Employer: _____

Email Address: _____

For a commercial or industrial customer

Applicant Legal Name (must be the same as that on your microFIT/FIT application)

Company Name: _____

Contact Person

Title: Mr. Miss Mrs. Ms.

First Name: _____ Last Name: _____

Phone Number: _____ Fax Number: _____

Email Address: _____



Appendix 3

Program Type

- FIT MicroFIT Net-Metering Non-exporting Other (specify)

HST Registrant?

- No Yes

Service Information

Date Service Required (dd/mm/yyyy):

Street Address: _____

City: _____

Postal Code: _____

Billing Address (if different from service address)

Street Address: _____

City: _____

Postal Code: _____

Owner's Signature

Date (dd/mm/yyyy)

Please Return Completed Application to:

GrandBridge Energy Inc.
Attn: Steve Faulkner C.Tech
Manager, Metering, Distributed Generation
Email: generation@grandbridgeenergy.com

Preliminary Consultation Information Request (PCIR)

OEB Template Version 2

Distributor Template Version 2026 R0

1. Instruction

The Applicant should only proceed with this form if the proposed DER project meets the following conditions:

- a) Has a capacity larger than 12kW (AC).
- b) Not a sole emergency backup generator during a power interruption to the distribution system.

For a micro DER project with a capacity size of 12kW or less, please review the Local Distribution Company (Distributor)'s website for application process.

The Applicant should complete the latest version of the PCIR form, and submit the form per the instruction provided on the Distributor's website. All fields are required, unless otherwise noted, to enable the preliminary connection assessment. The Applicant does not need to commit to any information provided in the PCIR. Changes can be made when applying for a Connection Impact Assessment (CIA). Please note that the preliminary consultation process does not consider the full range of technical evaluations that would be performed through a CIA. The PCR provides additional information on the potential complexity of the connection of the proposed DER. Capacity is not reserved upon completion of a Preliminary Consultation Report (PCR).

Please check the Independent Electricity System Operator (IESO)'s website for information on the System Impact Assessment if the Applicant plans to provide ancillary services.

All kW capacity information in this form should be in AC.

2. Distributor Contact Information

2.01 Contact Information			
A. Distributor Name	-	GrandBridge Energy Inc.	Pre-populated by Distributor
B. Department Name	-	Metering & DERs	Pre-populated by Distributor
C. Department Address	-	39 Glebe St	Pre-populated by Distributor
D. Department City & Postal Code	-	Cambridge, N1S 2L8	Pre-populated by Distributor
E. Department Fax	-		Pre-populated by Distributor (Optional)
F. Department Phone	-	519 621 3530 ext:2400 OR ext:5672	Pre-populated by Distributor
G. Department Email	-	generation@grandbridgeenergy.com	Pre-populated by Distributor

3. General

3.01 Application Information			
A. Project Name	-		-
B. Application Submission Date	Date		Format: YYYY-MM-DD
3.02 Applicant Information			
A. Applicant (Company Name)	-		-
B. Applicant Type	Select		-
C. Applicant Representative (Individual Name)	-		-
D. Applicant Address	-		Corporate Address (if applicable)
E. Applicant City	-		-
F. Applicant Postal Code	-		Format: A0A 0A0
G. Applicant Fax	-		Optional
H. Applicant Phone	-		Format: XXX-YYY-ZZZZ
I. Applicant Email	-		-

Appendix 4

Distributed Energy Resource (DER) Connection	Distributor: GrandBridge Energy Inc.
Preliminary Consultation Information Request (PCIR)	
<i>OEB Template Version 2</i>	
<i>Distributor Template Version 2026R0</i>	

4. Project Information

4.01 Project Nameplate & Type			
A. Proposed Capacity (Aggregate)	kW		<i>AC capacity</i>
B. Exporting/Non-Exporting	Select		<i>Indicate if capable of exporting to grid</i>
C. Proposed Export Capacity (Aggregate)	kW		<i>If capacity is different from Proposed Capacity</i>
D. Connection Type (Single/Three-Phase)	Select		-
E. Inverter-Based/Non-Inverter-Based	Select		-
4.02 Proposed DER Fuel/Energy Type			
Please use the selection below to identify the proposed DER fuel/energy type.			
A. Solar	kW		-
B. Wind	kW		-
C. Water (Hydroelectric)	kW		-
D. Biofuel/Biogas	kW		-
E. Thermal	kW		<i>Other than biofuel</i>
F. Energy Storage (including bi-directional EV)	kW		-
G. Other	Specify		<i>Enter specific technology type and kW information</i>

5. Site Information

5.01 Existing Account Holder			
A. Existing Account Number (if Applicable)	-		<i>Required if applicable</i>
B. Existing Account Holder Name (if Applicable)	-		<i>Required if applicable</i>
5.02 Site Information			
A. Site Address	-		<i>Location of proposed facility</i>
B. Site City/Town/Township	-		-
C. Site Postal Code	-		-
D. Site GPS Co-ordinates	-		<i>Required for rural locations</i>
5.03 Existing DERs at Site			
If the Applicant has existing DER(s) at the same project site, please provide information required below to ensure proper preliminary connection assessment. If there is a variety of fuel/energy types, please explain in section "6.01 Other Information" below.			
A. Existing DER Capacity (Aggregate)	kW		<i>Required if existing DER(s) installed</i>
B. Existing DER Connection (Single/Three-Phase)	Select		<i>Required if existing DER(s) installed</i>
C. Existing DER Type (Inverter/Non-Inverter)	Select		<i>Required if existing DER(s) installed</i>
D. Existing DER Intent (Exporting/Non-Exporting)	Select		<i>Required if existing DER(s) installed</i>

Preliminary Consultation Information Request (PCIR)

OEB Template Version 2

Distributor Template Version 2026 R0

6. Other Information

6.01 Other Information

A. In the comment box below, the Applicant can provide any additional information that is required as indicated in the above section(s) or considered beneficial for the purpose of obtaining a preliminary connection assessment.

B. If the Applicant chooses to provide accompanying documents, please list them below.

7. Distributor Office Use Only (Optional)

7.01 PCIR Status

A. Date Received	Date		<i>Completed by Distributor</i>
B. Date Returned Incomplete	Date		<i>Completed by Distributor</i>
C. Date Preliminary Consultation Report Issued	Date		<i>Completed by Distributor</i>



Connection Impact Assessment (CIA) Application

Metering & DERs

generation@grandbridgeenergy.com

519-621-3530 ext 2402



▶ ABOUT THIS FORM

This Connection Impact Assessment (CIA) application is to be completed by any proponent interested in connecting a Distributed Energy Resources (DER) with a project size over 12 kilowatts (kW) to GrandBridge Energy. This includes DER applying for a new CIA or for revision(s) to their original CIA. This form expresses an intent to enter into an agreement between GrandBridge Energy and the customer (or host customer* for non-exporting projects) for completion of a CIA associated with connecting a DER to the GrandBridge Energy distribution grid. The CIA Application shall be part of the required servicing (electrical installation, maintenance, and operating) agreements between GrandBridge Energy and the proponent. Through this process, GrandBridge Energy will be the proponent's contact with the transmission system provider (e.g. Hydro One Networks Inc.) and, if necessary, the provincial market operator, namely, the Independent Electricity System Operator (IESO).

For Non-exporting projects, the term "host customer" refers to the owner of the load facility. The term "DER owner" refers to the owner of the DER facility.

Emergency Backup Generators should use the Layout Application Form available at:

<https://grandbridgeenergy.com/customer-support/form-hub-energy-forms-grandbridge-energy/request-a-service-layout-form/>

▶ TECHNICAL REQUIREMENTS

For technical requirements of GrandBridge Energy's DER projects, refer to the "DER Technical Interconnection Requirements Interconnections at Voltages 50kV and Below", available at:
https://www.hydroone.com/businessservices/_generators_/Documents/Distributed%20Generation%20Technical%20Interconnection%20Requirements.pdf

▶ SUBMISSION INSTRUCTIONS

Please return the completed form, fees and other required documents by email to generation@grandbridgeenergy.com:

GrandBridge Energy
Attn: Generation Connection
generation@grandbridgeenergy.com
Generation Connection Application
39 Glebe St, PO Box 1060
Cambridge, ON N1R 5X6

▶ IMPORTANT NOTES

An engineering stamp and all red box fields (on electronic version of form) are mandatory. Incomplete applications may be returned by GrandBridge Energy and will result in delays in processing your application. Click the "Validate Form" button on the top right of this page to ensure all required information is filled. If any of the required fields are not applicable to your project, type "N/A" in any required text field or "0" in any required numerical field

- GrandBridge Energy specific requirements and notes are found in Sections S and T, respectively
- Applicants are cautioned NOT to incur major expenses until GrandBridge Energy approves to connect the proposed DER facility.
- All technical submissions (CIA Application, Single Line Diagrams, etc.) must be signed, dated and sealed by a licensed Ontario Professional Engineer (P.Eng.).
- The proponent will pay for the CIA according to the GrandBridge Energy CIA Fee Schedule.





- The siting restrictions in O. Reg. 274/18, which were administered by electricity distributors such as GrandBridge Energy, have been replaced by amendments to the *Planning Act* (Ontario) that puts siting and planning requirements for renewable DER facilities under municipal oversight. It is recommended that you discuss municipal permitting and approvals requirements with the planning department in the municipality where your DER project is located before you proceed.

▶ SECTION A: APPLICATION INFORMATION

Engineering Stamp <input type="text"/>	Application Type <i>choose one</i> <input type="text"/>	Date <i>mm/dd/yyyy</i> <input type="text"/>
	Program Type/Purpose <i>choose one</i> <input type="text"/>	Program Type (additional details) <input type="text"/>
	Project Name <input type="text"/>	
	IESO Contract Number <i>F-XXXXXX-XXX-XXX-XXX</i> <input type="text"/>	IESO Reference Number <i>FIT-XXXXXX</i> <input type="text"/>

Ontario Corporate Number or Business Identification Number <input type="text"/>	Proposed In Service Date <i>mm/dd/yyyy</i> <input type="text"/>
--	--

If this project is a subdivision project, please complete the following fields:

Subdivision Project Name <input type="text"/>	Number of Lots <input type="text"/>
--	--

For certain application type selections, please complete the required fields:

Original CIA Project ID # *XX,XXX*

Revised Fields *list the fields that have changed from your previous application*

▶ SECTION B: PROJECT LOCATION

Address <input type="text"/>	
City / Town / Township <input type="text"/>	Postal Code <input type="text"/>
Lot Number(s) <input type="text"/>	Concession Number(s) <input type="text"/>





SECTION C: CONTACT INFORMATION

CIA will be issued in the name of the host customer (load facility owner). All agreements (including CCA and DCA) are only made between GrandBridge Energy and the host customer. This section is strictly to gather contact information of some of the key contacts that are involved with the project.

Who is the single point of contact for this project?

Host Customer DER Owner (if different from host customer) Consultant

Please enter the following information about the **host customer** (load facility owner)

Contact Person

Company's Legal Name

Mailing Address *including postal code, P.O. Boxes and Rural Routes will not be accepted*

Work Telephone

Cell Phone

Fax Number

Email Address

Please enter the following information about the **DER owner** (if different from host customer)

Contact Person

Company's Legal Name

Mailing Address *including postal code, P.O. Boxes and Rural Routes will not be accepted*

Work Telephone

Cell Phone

Fax Number

Email Address

Please enter the following information about the **consultant**

Contact Person

Company's Legal Name

Mailing Address *including postal code, P.O. Boxes and Rural Routes will not be accepted*

Work Telephone

Cell Phone

Fax Number

Email Address





SECTION D: CUSTOMER STATUS

Is there an existing GrandBridge Energy account at the project location?

Yes No

Is the account holder aware of this application?

Yes No

Does your account fall within a residential-rate classification?

Yes No Do not Know

Existing Account Number

Account Holder Name

Does the account holder have an HST registration number?

Yes No

HST Number

SECTION E: EXISTING DER

Are there existing DER at the point of common coupling (PCC)?

Yes No

Existing Project Number

Existing Project Size (kW)

Program Type For Existing DER *choose one*

DER type: Synchronous Induction Inverter based Other

For synchronous units	For induction units	For inverter based units
Min. power limit for stable operation <i>kW</i> <input type="text"/>	Direct axis sub-transient reactance, $X''d$ <i>pu</i> <input type="text"/>	Inverter rating <i>kVA</i> <input type="text"/>
Direct axis sub-transient reactance, $X''d$ <i>pu</i> <input type="text"/>	Direct axis transient reactance, $X'd$ <i>pu</i> <input type="text"/>	Maximum continuous power output <i>kW</i> <input type="text"/>
Direct axis transient reactance, $X'd$ <i>pu</i> <input type="text"/>	Total PF correction installed <i>kVAR</i> <input type="text"/>	
Direct axis synchronous reactance, X_d <i>pu</i> <input type="text"/>		
Zero sequence reactance, X_0 <i>pu</i> <input type="text"/>		





SECTION F: PROJECT INFORMATION

Station Name *(optional to leave blank for behind the meter projects)*

Feeder *(optional to leave blank for behind the meter projects)*

Feeder Voltage (kV) *(optional to leave blank for behind the meter projects)*

Project Size (kW) *total maximum output capacity*

Equipment Capacity (kVA) *total equipment nameplate rating*

Type of Connection

Single Phase

Three Phase

If this is a solar project, please answer the following questions:

Mounting Type *select one*

If this is a water project, please answer the following questions:

Is your generation facility located on provincial Crown or federally-regulated lands?

Yes

No

Is water your primary energy source?

Yes

No

SECTION G: STATION SERVICE LOAD INFORMATION

The host customer's station service load details

*If there is an existing account at the project location, populating the fields in Section G is **Required** for GrandBridge Energy. Ensure selection below matches with this note.*

Required

Optional

Maximum Demand of Station Service Load of DER *kW*

Average Monthly Consumption *kWh*





SECTION H: CONNECTION INFORMATION

On a cut-out from the GrandBridge Energy DOM (Distribution Operating Map), or a site plan if a DOM is not made available by the LDC, provide the location of the generation facility with proposed line routings for connection to GrandBridge Energy’s distribution system. It should identify the Point of Expansion (POE), the Point of Common Coupling (PCC), the location of the generation facility, and (if applicable) the route of the new line between the generation facility and the POE (ie. on private property or public road/right-of-way). This is not required for existing load customers that are connecting a non-exporting generation, net metering generation or energy storage system behind their existing metered connection point. Please see “Appendix A” for a visual representation of POE and PCC.

DOM Drawing/Sketch Number

DOM Revision Number

Please provide an SLD of the Generator’s facilities, including the PCC, transformer and connecting station, feeder, and supply voltage.

SLD Drawing/Sketch Number

SLD Revision Number

POE Latitude *degree decimal format*

POE Longitude *degree decimal format*

PCC Latitude *degree decimal format*

PCC Longitude *degree decimal format*

Generation Facility Latitude *degree decimal format*

Generation Facility Longitude *degree decimal format*

Length of Line from POE to PCC *km*

Length of Line from PCC to Generation Facility *km*

Important: The line between the PCC and the Generation Facility must NOT be shared with any other DER owner (refer to Appendix A).

Conductor Type/Size *for the line between the PCC and the Generation Facility*

Generator Fault Contribution *with fault location at the PCC*

IMPORTANT NOTES:

If this project requires line expansion work between the POE and PCC, GrandBridge Energy will provide a cost estimate to construct any line located on public road right-of-way. The cost estimate will include a breakdown of uncontestable work (i.e. overbuild to existing line) that can only be performed by GrandBridge Energy, as well as contestable work (i.e. new construction/green-field) that may be performed by the Generator, their contractor or GrandBridge Energy. The design of uncontestable and contestable work shall conform to GrandBridge Energy specifications).

For Generator-owned line, the Generator may apply to construct the line on existing GrandBridge Energy-owned poles. This is known as an application for Joint Use (JU) of poles. If the application is accepted, GrandBridge Energy will provide the Generator with information on initial connection costs, annual pole-space rental and emergency service (ES) fees, and required JU & ES Agreements.





SECTION I: ENERGY STORAGE OR UPS

Please complete the following section if your project includes energy storage.

Number of Units

Inverter Unit Size enter zero if inverter is shared with generation unit(s)

Energy Storage Unit Size kWh

Total Energy Storage Size kWh

Energy Storage Facility Control Strategy

- Peak Shaving
- Dynamic VAR Support
- Frequency Support
- Other

Please submit a detailed description of the control strategy according to the templates in Appendix B. GrandBridge Energy reserves the right to modify the control strategy as part of its Detailed Technical Connection Assessment.

SECTION J: NON-EXPORTING/PEAK SHAVING

Please complete the following section if this is a non-exporting or peak shaving project

Operating Mode

- Parallel
- Non-Parallel

Transition Type

- Closed "make before break"
- Open "break before make"

Time that generator remains parallel to grid closed transition only, ms

For non-parallel non-exporting, SCADA monitoring and Gross Load Billing (GLB) may apply. For non-exporting generation facilities, please attach a schedule of the forecasted maximum generation output (as a function of loading of the facility). At a minimum, include the forecasted generation output information (i.e. Watts and VARs) during the minimum and maximum of the load facility to which the non-exporting generator is connecting (see Appendix C for template)





SECTION K: DER CHARACTERISTICS

For facilities with multiple generators: If your generators have different characteristics, please use the "Add Page" button and provide the characteristics for each generator on the additional pages.

DER type: Synchronous Induction Inverter based Other

Number of Generating Units Rated Capacity of Each Unit kW kVA DER Output Voltage in kV

Manufacturer Type or Model Number

If Power Conversion Type is "Other", please provide values equivalent to a Synchronous or Induction type generator.

Maximum Starting In-rush Current multiple of full load current, pu Generator Winding Connection Delta Star

Neutral Grounding Method for star winding connection only Impedance R in ohms Impedance X in ohms

Limits of range of reactive power at the machine output:

Lagging over-excited, kVAR Lagging Power Factor Leading under-excited, kVAR Leading Power Factor

Limits of range of reactive power at the PCC:

Lagging over-excited, kVAR Lagging Power Factor Leading under-excited, kVAR Leading Power Factor

For synchronous units	For induction units
Nominal Machine Voltage <input type="text"/> kV (LL)	Nominal Machine Voltage <input type="text"/> kV (LL)
Unsaturated Reactance <input type="text"/> kVA Base	Unsaturated Reactance <input type="text"/> kVA Base
Unsaturated Reactance <input type="text"/> kV Base	Unsaturated Reactance <input type="text"/> kV Base
Direct Axis Subtransient Reactance, Xd'' <input type="text"/> pu	Direct Axis Subtransient Reactance, Xd'' <input type="text"/> pu
Direct Axis Transient Reactance, Xd' <input type="text"/> pu	
Direct Axis Synchronous Reactance, Xd <input type="text"/> pu	
Subtransient Time, Td'' <input type="text"/> ms	
Zero Sequence Reactance, X0 <input type="text"/> pu	





SECTION L: INTERFACE TRANSFORMER
The transformer connecting to the GrandBridge Energy distribution system

Transformer Ownership
 Customer GrandBridge Energy

Transformer Rating *KVA*

Transformer Type
 Single Phase Three Phase

Nominal Voltage of High Voltage Winding *kV*

Nominal Voltage of Low Voltage Winding *kV*

Impedance Base (if different than ratings above)
 kVA Base kV Base

Impedance (R) *pu* Impedance (X) *pu* OR Impedance (Z%) %

High Voltage Winding Connection
 Delta Star

High Voltage Grounding Method *for star winding connection only*
 Solid Ungrounded Impedance

Star Impedance R *in ohms* Star Impedance X *in ohms*

Low Voltage Winding Connection
 Delta Star

Low Voltage Grounding Method *for star winding connection only*
 Solid Ungrounded Impedance

Star Impedance R *in ohms* Star Impedance X *in ohms*

Notes

The term "High Voltage" refers to the connection voltage to GrandBridge Energy's distribution system and "Low Voltage" refers to the generation or any other intermediate voltage.

Providing a photo of transformer equipment along with this application may help expedite your application.





SECTION M: INTERMEDIATE TRANSFORMER

Transformer between the interface transformer and DER

Please complete the following section if your project includes an intermediate transformer.

Do you intend to install an intermediate transformer?

Yes No

Transformer Rating *kVA*

Transformer Type

Single Phase Three Phase

Nominal Voltage of High Voltage Winding *kV*

Nominal Voltage of Low Voltage Winding *kV*

Impedance

 kV Base

Impedance R *pu*

Impedance X *pu*

High Voltage Winding Connection

Delta Star

High Voltage Grounding Method *for star winding connection only*

Solid Ungrounded Impedance

Star Impedance R *in ohms*

Star Impedance X *in ohms*

Low Voltage Winding Connection

Delta Star

Low Voltage Grounding Method *for star winding connection only*

Solid Ungrounded Impedance

Star Impedance R *in ohms*

Star Impedance X *in ohms*

Notes:

The term "High Voltage" refers to the connection voltage to GrandBridge Energy's distribution system and "Low Voltage" refers to the generation or any other intermediate voltage.

SECTION N: HIGH-VOLTAGE GROUNDING TRANSFORMER

Please complete the following section if your project includes a high-voltage grounding transformer.

Do you have a high-voltage grounding transformer?

Yes No

Transformer Type *select one*

Zig-Zag Star-Delta

Zero Sequence Impedance (Z0) R *ohms*

Zero Sequence Impedance (Z0) X *ohms*



**▶ SECTION O: SUBMISSION CHECKLIST**

Please ensure the following items are completed prior to submission. Your application may not be processed if any part is omitted or incomplete:

- Payment in full including applicable taxes (by cheque payable to “GrandBridge Energy”)
- Completed Form B stamped by a Professional Engineer
- Single Line Diagram (SLD) of the Generator’s facilities, must be stamped by a Professional Engineer
- Protection Philosophy
- Distribution Operating Map (DOM) and/or Site Plan *(not required for existing load customers that are connecting a non-exporting generation, net metering generation or energy storage system behind their existing metered connection point)*
- Non-exporting Generation Facility’s load and generation schedules (if applicable)
- Non-exporting Generation Facility’s mode of operation (if applicable)
- Energy Storage Facility operating strategy description an parameters (if applicable)
- Emergency Backup Generation Facility’s mode of operation (if applicable)

▶ SECTION P: CIA APPLICATION FEE CHECKLIST

Please ensure the following items are completed prior to submission. Your application will not be processed if any part is omitted or incomplete. Check all that apply:

- Applicable CIA Fee**
See the [Connection Impact Assessment Fee Schedule](#) on our website for costs. Please enter the amount from the fee schedule. \$ +HST
- Transmission Customer Impact Assessment (TxCIA) Fee (if applicable)**
A TxCIA is also required if the total nameplate generation of the project is greater than 10MW. \$ +HST
- IESO System Impact Assessment (SIA) Fee (if applicable)**
An SIA deposit is required if the total nameplate generation of the project is greater than 10MW. The total cost of the SIA will be Trued Up/Down upon the receipt of the SIA from the IESO. See the [IESO’s SIA Application](#) for costs. \$





SECTION Q: ATTACHMENTS

Attached Documents / Drawings

Item #	Description	Document #	# of Pages

SECTION R: NOTES



**▶ SECTION S: GrandBridge Energy Specific Required Fields**

This section contains specific information that is required by GrandBridge Energy. Please read Section T notes regarding this section if you need further details.

What is the barcode of the nearest pole serving the project location?

GrandBridge Energy Account Number *if transformer is owned by GrandBridge Energy*

▶ SECTION T: GrandBridge Energy Specific Additional Notes

Section A: no additional notes

Section B: no additional notes

Section C: no additional notes

Section D: no additional notes

Section E: no additional notes

Section F: no additional notes

Section G: no additional notes

Section H: no additional notes

Section I: no additional notes

Section J: no additional notes

Section K: no additional notes

Section L: no additional notes

Section M: no additional notes

Section N: no additional notes

Section O: for new DER site, Distribution Operating Map (DOM) is required by GrandBridge Energy in addition to Site Plan

Section P: When there is an upstream LDC, an additional fee will be required for costs associated with this LDC's CIA.

Section Q: no additional notes

Section R: no additional notes

Section S: - For question: "What is the barcode of the nearest pole serving the project location?", this is only applicable if you choose "No" to question: "Is there an existing GrandBridge Energy account at the project location?" in Section D

- For question: "GrandBridge Energy Account Number (if transformer is owned by GrandBridge Energy)", this is only applicable if you answer "GrandBridge Energy" to question: "Transformer Ownership" in Section L.





► **APPENDIX A - FIGURES & DIAGRAMS**

Figure A1: Where There is No New GrandBridge Energy Owned Line Expansion

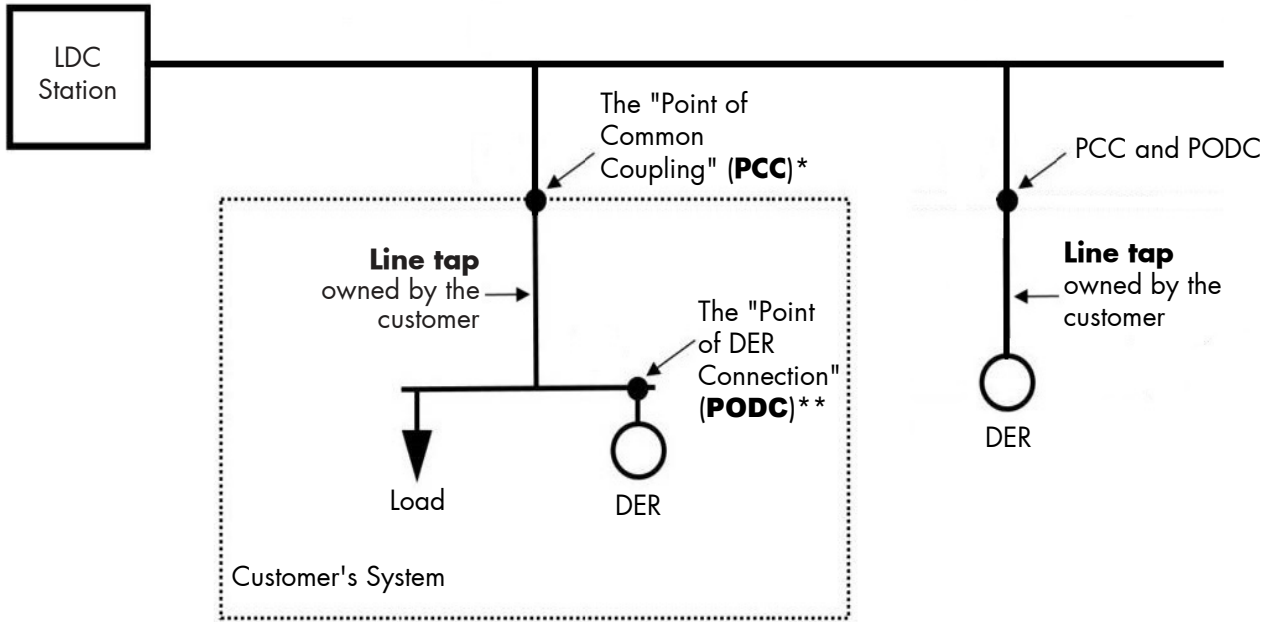

*PCC: the point where the customer facility connects to the LDC owned system

**PODC: the point where the DER unit(s)'s interconnection system connects the DER unit(s) to the DER facility.

Figure A2: Where There is a New GrandBridge Energy Owned Line Expansion

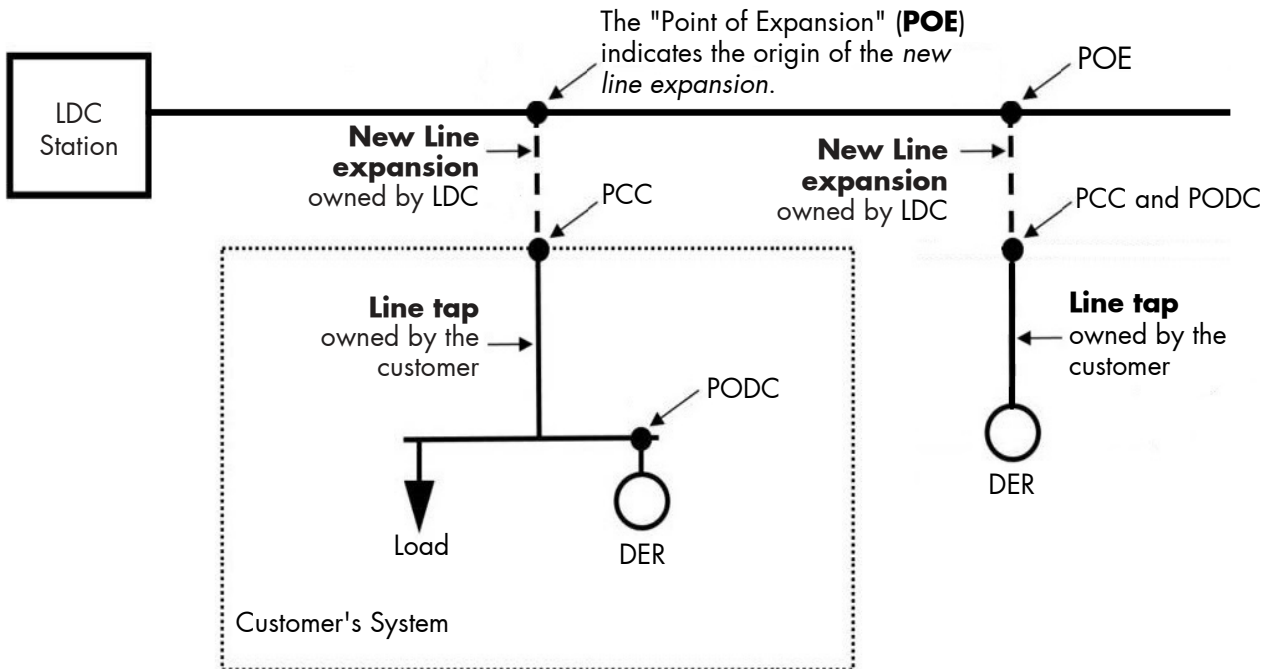



► APPENDIX B - MINIMUM CONTROL STRATEGY INFORMATION FOR ENERGY STORAGE FACILITIES OR OTHER TECHNOLOGIES

Figure B1: Peak Shaving

Peak Shaving			
Description of Control Strategy			
When Operating as a Load			
Switch In Time	Switch Out Time	Load kW (peak)	Load kVAR (peak, leading/lagging)
When Operating as a Generator			
Switch In Time	Switch Out Time	Generation kW (peak)	Generation kVAR (peak, leading/lagging)

Figure B2: Dynamic VAR Support

Dynamic VAR Support			
Description of Control Strategy			
Switch In Condition	Switch Out Condition	Generation kW (peak)	Generation kVAR (peak, leading/lagging)

Figure B3: Frequency Support

Frequency Support			
Description of Control Strategy			
Switch In Condition	Switch Out Condition	Generation kW (peak)	Generation kVAR (peak, leading/lagging)

Figure B4: Other Control Strategies

Other	
Description of Control Strategy and Relevant Operating Parameters	



**▶ APPENDIX C - NON-EXPORTING FIGURES****Figure C1: Example Schedule With Minimum Information Required for Non-exporting Projects**

	Load of Facility (kW)	Load of Facility (kVAR, lead or lag)	Generation Output (kW)	Generation Output (kVAR, lead or lag)
Minimum Load				
Maximum Load				

