



# Metering Specifications

The City of Brantford, The City of Cambridge, The County of Brant, and The Township of North Dumfries

**EFFECTIVE: June 01, 2023**

See GrandBridge Energy Inc., web site for the latest revisions at [www.grandbridgeenergy.com](http://www.grandbridgeenergy.com)  
Comments on this document can be e-mailed to [customercare@grandbridgeenergy.com](mailto:customercare@grandbridgeenergy.com)

Approved by Umar Waqas, P.Eng. *Umar Waqas, P.Eng*

Approval is given in accordance with Ontario Regulation 22/04. There are no undue hazards.  
It is suitable for the intended application and will be adequately inspected.



## Table of Contents

Preface .....	3
1.0 General .....	4
2.0 Responsibilities .....	8
2.1 GrandBridge Energy Inc.....	8
2.2 The Customer .....	8
3.0 Service Identification .....	8
4.0 Meter Equipment Requirements.....	9
4.1 Single Phase Metering Requirements .....	10
4.1.1 225-600 Amp Single Phase Services .....	10
4.2 Single Phase Central Metering .....	11
4.3 Multi-Unit Sites .....	11
4.3.1 Apartment Building Metering.....	12
4.3.3 Shopping Plaza and Industrial Mall Metering.....	12
4.4 Three Phase Metering Requirements .....	12
4.4.1 Three Phase Services without Switchgear .....	13
4.4.2 Three Phase Services with Switchgear.....	14
4.5 Three Phase Central Metering .....	15
4.6 Primary Metering .....	16
4.7 Interval Metering .....	17
4.8 Metering Pulse Outputs .....	17
Appendix A: GrandBridge Energy Metering Standard Drawings: MS-001 to MS-023 .....	18
Appendix B: GrandBridge Energy Metering Pulse Output(s) Access Agreement .....	43
Table 1: GrandBridge Energy Inc. Approved Meter Bases.....	47



## Preface

This specification prescribes the requirements for GrandBridge Energy Inc. (formerly Energy + Inc., and Brantford Power Inc.) metering equipment installation. It is the Customer's and/or their Electrician/Contractor's responsibility to familiarize themselves with these specifications.

GrandBridge Energy Inc. (GBE) reserves the right to refuse to energize any part of the electrical plant that does not conform to these specifications. GBE assumes no responsibility whatsoever for the cost of repairs, or delays in energizing the system incurred as a result of disregarding these specifications.

The latest edition of the Ontario Electrical Safety Code shall apply unless otherwise stated in these specifications. The Customer and its agents are to familiarize themselves with, and abide by, all relevant Provincial Statutes and Municipal By-Laws. Such relevant regulations include in part, the Occupational Health and Safety Act and Regulations for Construction Projects. Also applicable are City of Cambridge, Township of North Dumfries, Region of Waterloo, County of Brant, and City of Brantford By-Laws.

GBE is regulated by the Ontario Energy Board (OEB) and complies with the new OEB requirements regarding the calculation of the charges payable by (or refunded to) the Customer. On September 29, 2000, the OEB issued the following decision:

“In order to promote stability and consistency among distributors with respect to capital contribution charges, the Board finds that the provisions in the Distribution System Code that determine whether capital contributions should be collected and the methodology and assumptions for an economic evaluation are in force upon the issuance of this decision.”

Refer to the GBE Economic Evaluation Model Policy for more information about charges or rebates. **This policy is updated regularly to reflect current cost and rate projections.**



## 1.0 General

This section refers to the general metering requirements applicable in most service applications. Further details and requirements are given in Sections [2](#), [3](#) and [4](#).

GBE will supply, install, own, and maintain all meters, instrument transformers, ancillary devices, secondary wiring, and seals required for revenue metering.

Metering will typically be done on the low voltage side of the GBE or customer owned transformer (“secondary metering”). Primary metering may be provided at the discretion of GBE. Detailed drawings showing the metering provision and arrangement for service mains more than 600A and/or 600V shall be submitted to GBE for approval before building construction begins. Additional standards and requirements for services metered above 600V will be made available upon request.

Additional metering requirements are listed in the Distribution System Code. Metered Market Participants in the Independent Electricity System Operator (“IESO”) administered wholesale market must meet or exceed all IESO metering requirements.

GBE shall have access to Customer property to install, read, and maintain its metering equipment, in accordance with Section 40 of the Electricity Act.

GBE’s Economic Evaluation Model Policy applies to metering. Please ask GBE for a copy of the latest edition of this document.

1.1 GBE will typically install metering equipment at the Customer supply voltage. The Customer must provide a convenient and safe location satisfactory to GBE for the installation of meters, wires, and ancillary equipment. Meters for new or upgraded residential services will be mounted outdoors on a meter socket approved by GBE (Table 1). The meter base cover plate must be removable (i.e., not enclosed) to allow GBE maintenance access.

1.2 The Customer is required to supply and install a GBE approved meter socket for the use of GBE’s self-contained socket meters.

1.3 No person, except those authorized by GBE, may remove, connect, or otherwise interfere with GBE’s meters, wires, ancillary equipment, or seals.

1.4 The Customer will be responsible for the care and safekeeping of GBE meters, wires, and ancillary equipment on the Customer’s premises. If any GBE equipment installed on Customer premises is damaged, destroyed, or lost other than by ordinary wear and tear, wind or lightning, the Customer will be liable to pay to GBE the value of such equipment, or at the option of GBE, the cost of repairing the same.

1.5 Any compartments, cabinets, boxes, sockets, or other workspace provided by the Customer for the installation of GBE’s metering equipment shall be for the exclusive use of GBE. No equipment, other than that provided and installed by GBE, may be installed in any part of the GBE metering workspace (defined in Section 1.10).

1.6 In order to preserve the integrity and accuracy of GBE’s metering systems, no devices other than those required for GBE’s purposes shall be permitted to be connected to the metering circuits. Any metering or load control equipment required by the Customer must be connected to the Customer’s own current and voltage transformers which must be installed on the load side of GBE’s metering equipment. Any secondary arresters, power factor correction capacitors, ground fault indicator lights or other Customer equipment must also be connected on the load side of GBE’s metering equipment. The Customer’s own metering or load control equipment cannot be installed in



the same metering cabinet, or metering switchgear cell, as those of GBE. All Customer connections shall be made to the load side of GBE's metering.

1.7 Normally, only one service and one metering location will be provided to a property. Should more than one meter be required, the meters must be grouped in a single meter room on the property. However, consideration may be given to providing multiple services and/or multiple meter rooms on a property under one ownership if there are economic and/or electrical advantages to GBE in doing so. This is typically done only in the cases of large commercial, industrial or apartment/condominium developments where it isn't practical for GBE to provide only one service or meter room.

1.8 If a separate service for a fire pump has been deemed necessary to comply with legislation, codes or regulations under emergency conditions involving a fire, GBE will offer it subject to the following additional requirements:

- A single line diagram showing the connection of the fire pump and meter base voltage and current ratings shall be submitted to GBE.
- The main disconnect for the fire pump service shall be in the same room as the main breaker for the overall service.
- Laminated warning cards must be located at both the main disconnect for the fire pump service and at the main disconnect for the main secondary service (permanently affixed). They must be red with white lettering and the lettering must be a minimum of 12.7mm (0.5") in size. Wording on these cards must be "Fire Pump Installed Ahead of Main Breaker. Two (2) separate points of secondary supply exist in this room. There is a possibility of electrical back feed."

1.9 Central metering (the installation of instrument transformers at the transformer location to meter secondary cables running to two or more buildings on the same property and is typically installed in rural areas at the transformer pole) may be provided at the discretion of GBE. Refer to Section [4.2](#), [4.5](#), and [Appendix A](#), Drawings "[MS-011](#), [MS-012](#), [MS-020](#), [MS-021](#) and [MS-022](#)" for complete details and charges applicable to the Customer.

1.10 The location allocated by the Customer for GBE metering shall provide direct access for GBE staff and shall be subject to satisfactory environmental conditions, some of which are:

- Maintain a safe and adequate working space in front of equipment, not less than 1m (39") and a minimum ceiling height of 2.1m (6'11") for the full width of the installation, with a minimum width of 1m (39"). This space shall not be used for storage, etc. Noticeable, repetitive obstruction of this working space can be enforced by GBE notifying the Fire Department and Electrical Safety Authority.
- Maintain an unobstructed working space in front of equipment, free from, or protected against, the adverse effects of moving machinery, vibration, dust, moisture, or fumes.

1.11 Where there is the possibility of danger to GBE employees or damage to equipment from moving machinery, dust, fumes, moisture, etc., protective arrangements satisfactory to both GBE and the Electrical Safety Authority shall be made.

1.12 Where excessive vibration may affect or damage GBE metering equipment, adequate shock absorber mounting suitable to GBE will be provided and installed by the Customer. The Customer or their contractor will contact GBE when there is the possibility that such conditions may occur.



1.13 If, in the opinion of GBE, building additions, alterations, fencing, tree growth or other obstruction, etc. render the meter inaccessible for reading and servicing, the meter will be relocated to a GBE approved location at the Customer's expense. Where such a condition exists, the Customer will be granted 30 days to relocate the meter or ensure suitable access.

1.14 When a residential Customer is upgrading their service, and the meter is inside, it must be moved outside to a GBE approved location at the Customer's expense. Sections [1.19](#) and [4.1](#) provide further details about the required meter location.

1.15 Meter bases shall be installed ahead of (on the line side of) the main disconnect switch for single phase services (unless approval is obtained from GBE for specific circumstances – i.e., multi-unit inside metering).

1.16 Meter bases shall be installed downstream (on the load side of) the main disconnect for three phase services.

1.17 Each detached, semi-detached or row housing unit (freehold or condominium) will be separately metered by a meter that is located outside. For condominium row housing, all meter bases for each block must be installed using GBE approved ganged meter bases located on one or both ends of each block (as per the design drawing). The Customer is responsible for the extension of the unit services from the meter to the individual units. For freehold units, each meter must be mounted separately on each individual unit. The individual units must be numbered and identified in accordance with Section [4.3](#) and Appendix A, Drawing "[MS-001](#)". Refer to Section [4.3](#) for further details on multi-unit metering.

1.18 When meters are to be mounted outside, the following general guidelines apply. Customer shall consult with GBE prior to start of work to determine specific metering requirements:

- Meters are to be mounted at a height of 1.5m (5'0")  $\pm$  150mm (6") when measured from finished grade to the center of the meter face/glass.
- Meter bases shall be mounted on the exterior of the building within 1.5m (5') of the front corner of the building. The front of the building is that side which is nearest to GBE's main lines.
- No part of the meter base is permitted to be above gas meter, central air conditioners, window wells etc.
- For overhead services, the meter base must meet the requirements of the Electrical Safety Authority. For underground services, the meter base must meet the requirements of the Electrical Safety Authority and be on the approved GBE meter base list. For the current list of approved meter bases for underground services refer to [Table 1](#). For 400A single-phase services, refer to Sections [4.1.1](#) and [4.2](#).
- For new underground services, a 50mm (2") conduit is to be supplied and installed by the Customer from the meter base to a point 500mm (20") to 600mm (24") below finished grade. All site installations will be considered as "Safe Work Site Areas". A safe work site area will be determined when the meter installer is on location. If a work site is deemed unsafe or there are safety concerns by the installer, there will be a delay in the installation of the meter.
- If a meter installer must enter the building and access the electrical panel other than on the main floor, there must be a proper stairway with a handrail that leads to the location of the electrical panel.



- It is recommended the customer, or a representative is present at the time of the meter installation to clarify/assist with any issues that may delay meter installation. Additional calls to a site may prompt a service charge billed to the owner.
- A “temporary” finished grade may be permitted only if the meter installer agrees the grade is acceptable and the surface area is safe to work on. This temporary grade condition must still meet the terms of section [1.10](#). This is only a temporary condition until final grading can be completed.
- The “permanent” finished grade should not be altered in any way after the meter has been installed.

1.19 When meters are to be mounted inside, the following conditions general guidelines apply. Customer shall consult with GBE prior to start of work to determine specific metering requirements:

- Meters are to be mounted at a height of 1.7m (5'6")  $\pm$  150mm (6") when measured from finished floor elevation to the center of the meter face/glass. If a metering centre is used, the minimum height allowed for the bottom row of meters is 0.58m (23") and the maximum height allowed for the top row of meters is 1.7m (5'6") by 150mm (6") as shown in Appendix A, Drawing "[MS-014](#)". Both dimensions are measured from finished floor elevation to the center of the meter face/glass. It is GBE's preference to have the middle meter locations filled first.
- Metering cabinets, if required, shall be mounted at 1.8m (6')  $\pm$  0.1m (4") from the finished floor elevation to the top of the metering cabinet.
- The Customer's main switch shall be installed so that the top of the switch is 1.8m (6') or less from the finished floor elevation. The Customer's main switch shall permit the sealing and padlocking of the handle in the "open" position and the cover or door in the "closed" position.
- Lighting levels of at least 6 lux (65 foot-candles) shall be maintained.
- No water, gas, sewer, or other pipes, communications wire or equipment will be permitted to encroach on the safe working space requirements, as viewed by GBE, of the metering.
- Meter rooms, for multi-unit metering, shall be accessible to GBE via an outside lockable door at grade level. The minimum door dimensions shall be 2m (6'-8") by 0.81m (2'-8"). The Customer shall be responsible for supplying a key to GBE. GBE may request that the lock be keyed to GBE specifications. A key lock box may be requested by GBE to be installed on site by the customer. In specific instances and at the sole discretion of GBE, the requirement for an outside door may be waived (i.e., a high-rise apartment building where meter rooms may be required to be located on more than one floor).

1.20 Interval meters will be installed for all new or upgraded services where the monthly average peak billed demand over a calendar year is forecast to be 50 kW or greater. For any other Customer, please contact GBE for availability.

1.21 The Customer must provide or arrange free, safe, and unobstructed access during regular business hours to any authorized representative of GBE for the purpose of meter reading, meter changing, or meter inspection. Where premises are closed during GBE's normal business hours, the Customer must, on reasonable notice, arrange such access at a mutually convenient time. This access is in accordance with Section 40 of the Electricity Act.



1.22 The Customer and or its agent shall submit to GBE all required switchgear and electrical single line drawings in a timely manner to allow for GBE's reviews and approvals. Drawing submissions in electronic format must be in either AutoCAD ".dwg" or ".pdf" format.

1.23 All drawings contained within this document have been reviewed and approved by a Professional Engineer.

In all cases, the Customer shall consult with GBE prior to the start of work to determine the specific metering requirements.

## 2.0 Responsibilities

### 2.1 GrandBridge Energy Inc.

GBE, when requested, shall supply, install, and maintain revenue meters, instrument transformers, interconnecting wiring and any related equipment for revenue metering installation, in a timely manner upon compliance with GBE's Metering Specifications.

### 2.2 The Customer

2.2.1 The Customer must provide a convenient and safe location satisfactory to GBE for the installation of meters, wires, and ancillary equipment. No person, except those authorized by GBE, may remove, connect, or otherwise interfere with GBE's meters, wires, ancillary equipment, or seals. The Customer will be responsible for the care and safekeeping of GBE meters, wires, and ancillary equipment on the Customer's premises. If any GBE equipment installed on Customer premises is damaged, destroyed, or lost other than by ordinary wear and tear, wind or lightning, the Customer will be liable to pay to GBE the value of such equipment, or at the option of GBE, the cost of repairing the same.

2.2.2 The Customer's own metering or load control equipment cannot be installed in the same metering cabinet, or metering switchgear cell, as those of GBE. All Customer connections shall be made to the load side of GBE's metering. Any metering or load control equipment required by the Customer must be connected to the Customer's own current and voltage transformers which must be installed on the load side of GBE's metering equipment. Any secondary arresters, power factor correction capacitors, ground fault indicator lights or other Customer equipment must also be connected on the load side of GBE's metering equipment.

2.2.3 The Customer must provide or arrange free, safe, and unobstructed access during regular business hours to any authorized representative of GBE for the purpose of meter reading, meter changing, or meter inspection. Where premises are closed during GBE's normal business hours, the Customer must, on reasonable notice, arrange such access at a mutually convenient time. This access is in accordance with Section 40 of the Electricity Act.

2.2.4 The Customer shall comply with the specifications for each type of electrical service listed within these Metering Specification

## 3.0 Service Identification

With regards to multi-unit buildings, the Customer shall permanently and legibly identify all metered services with respect to unit number and/or civic address. The units, meter bases and main disconnect switches must have permanent unit numbers installed prior to the installation of any metering apparatus according to Appendix A,



Drawing "[MS-001](#)". The Customer must inform GBE in writing if changes are made to unit numbering and will be liable to pay GBE any incurred costs as a result of unit re-numbering.

## 4.0 Meter Equipment Requirements

This section provides specific technical details about certain service applications. General details are covered in Sections [1](#), [2](#) and [3](#).

As it relates to personnel safety, we wish to repeat the following from Section [1.10](#):

The location allocated by the Customer for GBE metering shall provide direct access for GBE staff and shall be subject to satisfactory environmental conditions, some of which are:

- Maintain a safe and adequate working space in front of equipment, not less than 1m (39") and a minimum ceiling height of 2.1m (83") for the full width of the installation. This space shall not be used for storage, etc. Noticeable, repetitive obstruction of this working space can be enforced by GBE notifying the Fire Department and Electrical Safety Authority.
- Maintain an unobstructed working space in front of equipment that is free from or protected against the adverse effects of moving machinery, vibration, dust, moisture, or fumes.

The Customer and/or its agent shall submit to GBE all required switchgear and electrical single line drawings in a timely manner to allow for GBE's reviews and approvals. Drawing submissions in electronic format must be in either AutoCAD ".dwg" or ".pdf" format.

The location for metering equipment will be on the low voltage side of the GBE step-down transformer (this is termed "secondary metering"). For primary metering details, please refer to Section [4.6](#).

Detailed drawings showing the metering provision and arrangement for service mains more than 600 A and/or 600 V shall be submitted to GBE for approval before building construction begins. Additional standards and requirements for services metered above 600 V can be made available upon request.

Barriers are required in each section of switchgear or service entrance equipment between metered and un-metered conductors and/or between sections reserved for GBE and Customer use.

The acceptable limits for metering cabinet mounting heights are at 1.8m (6')  $\pm$  0.1m (4") from the finished floor elevation to the top of metering cabinet. Refer to Sections [4.4.1](#) and Appendix A, Drawing "[MS-017](#)" for the metering cabinet and equipment layout.

Side-hinged doors shall be installed over all live electrical equipment where GBE personnel may be required to work (i.e., line splitters, un-metered sections of switchgear, breakers, switches, metering compartments, meter cabinets and enclosures). These hinged doors shall have provision for sealing and padlocking. Where bolts are used, they shall be of the captive knurled type. All outer-hinged doors shall open no less than 135°. All inner-hinged doors shall open to a full 90°.

Any conduits for the exclusive use of Utility shall have no more than three 90°-degree bends. No fittings with removable covers are permitted. At GBE's request the customer or contractor shall install nylon or polypropylene pull line in the conduit with an excess of 200mm (8") loop left at each end.



## 4.1 Single Phase Metering Requirements

The meter location shall be outside, and the following conditions apply:

- Meters are to be mounted at a height of 1.5m (5'0")  $\pm$  150mm (6") when measured from finished grade to the center of the meter face/glass.
- Meter bases shall be mounted on the exterior of the building within 1.5m (5') of the front corner of the building. The front of the building is that side which is nearest to GBE's main lines.
- No part of the meter base is permitted to be above gas meter, central air conditioners, window wells etc.
- All site installations will be considered as "Safe Work Site Areas". A safe work site area will be determined once a meter installer is on-site. If a work site is deemed unsafe or there are safety concerns by the installer, there will be a delay in the installation of the meter.
- If GBE staff must enter the building and access the electrical panel other than on the main floor, there must be a proper stairway with a handrail that leads to the location of the electrical panel.
- For multiple units, the customer or a representative must be present at the time of the meter installation and assist in the verification of each unit. The Metering Department at GBE needs to be notified to arrange a day and time (during normal working hours) to meet on site.

For overhead services, the meter base must meet the requirements of the Electrical Safety Authority.

For underground services, the meter base must meet the requirements of the Electrical Safety Authority and be on the approved GBE list. For the current list of approved meter bases for underground services refer to [Table 1](#).

The meter base must be equipped with tunnel type connectors approved for GBE's copper or aluminium cables and be equipped with a screw-type sealing ring.

When a residential Customer is upgrading their service, or adding generation, and the meter is inside, the meter shall be moved outside at the Customer's expense. Underground services must have a 200A meter base supplied and installed on the building in accordance with GBE's standard requirements. For underground or overhead service meter relocations refer to Appendix A, Drawing "[MS-004](#)".

Each detached, semi-detached, or linear row-housing unit shall be separately metered.

### 4.1.1 225-600 Amp Single Phase Services

For single-phase services greater than 225 Amp and less than or equal to 600 Amp, there are 2 main options:

#### 1) 225A to 400A single phase services:

- Use of a transformer-type combination meter base enclosure. Refer to Appendix A, Drawings "[MS-008](#), [MS-009](#), or [MS-010](#)".
- Customer to supply and install combination meter base enclosure with pre-wired current transformer, located outside, and complete with all lugs. GBE approved meter bases are listed in [Table 1](#).



- The 5-jaw meter base must be equipped with an automatic bypass for the current circuit on the left side, with the 5th jaw located at the 9 o'clock position.

## 2) 225A to 600A single phase services:

- See section [4.2](#) for single phase central metered services.
- Refer to Appendix A, Drawing "[MS-011](#)".

## 4.2 Single Phase Central Metering

Central metering may be provided at the discretion of GBE for rural services 225A to 600A single phase, to two or more buildings.

Refer to Appendix A, Drawings "[MS-011](#) or [MS-012](#)".

- The Customer will supply and install an approved 5-jaw (5th jaw at 9 o'clock position) meter base with automatic bypass at the current circuit on the left side. See [Table 1](#) for approved meter bases.

For pole mounted central metering installations, all central metering equipment will be located on the transformer pole. The pole will be a minimum 40' Class 3 Wood pole, supplied and installed by the Customer.

- The Customer will supply and install a continuous 32mm (1¼") EMT OR PVC conduit from the meter cabinet up the pole to a point 300mm (12") above the neutral wire, complete with weather head.

For pad mounted central metering installations, the CTs shall be located within the GBE pad mount transformer. The meter shall be located on 6"x 6" pressure treated post or a freestanding meter base structure.

- The Customer will supply and install a continuous 25mm (1") EMT OR PVC conduit from the meter base underground into the transformer vault at a minimum depth of 0.76m (30") below finished grade. The

Economic Evaluation Model would apply to GBE's costs.

## 4.3 Multi-Unit Sites

Regardless of the style of the multi-unit site, the following requirements apply to all multi-unit buildings:

- Prior to issuing a Service Order to have the service energized and metering equipment installed, the property owner must contact GBE's Customer Service Department and sign both the "Application for Electrical Service and Energy" and "Multi-Unit Conditions of Service" forms.
- The developer and/or electrician shall provide GBE with the following, prior to the service being energized:
  - All keys required to gain access to the metering room.
  - A copy of the building layout, indicating the municipal address and permanent unit numbers, for each floor if applicable, duly signed by the electrician or developer as correct.
  - A copy of the meter panel layout, indicating the correct corresponding permanent unit numbers, for each floor if applicable, duly signed by the electrician or developer as correct.



- The units, doors, meter bases and main disconnect switches must have permanent unit numbers installed prior to the installation of any metering apparatus according to Appendix A, Drawing "[MS-001](#)".

**No meters will be installed unless these requirements have been met.**

For multiple units, the customer or a representative must be present at the time of the meter installation and assist in the verification of each unit. The Metering Department at GBE needs to be notified to arrange a day and time (during normal working hours) to meet on site

Several examples of the equipment layout for multi-unit metering are shown in Appendix A, Drawings "[MS-001](#), [MS-005](#), [MS-006](#), [MS-007](#), [MS-013](#), [MS-014](#), and [MS-019](#)".

If a metering centre is used, the minimum height allowed for the bottom row of meters is 0.6m (24") and the maximum height allowed for the top row of meters is 1.7m (5'6")  $\pm$  150mm (6") as shown in Appendix A, Drawing "[MS-014](#)". Both dimensions are measured from finished floor elevation to the center of the meter face/glass. It is GBE's preference to have the middle meter locations filled first. Drawing "[MS-014](#)" specifically relates to the use of a metering centre. The main switch for each sub-service must have provisions for sealing by GBE.

For the current list of approved 120/240V single-phase meter bases for multi-unit services refer to [Table 1](#).

All condominium dwelling units including high rise buildings will be metered individually.

#### 4.3.1 Apartment Building Metering

All new apartment buildings may be individually metered by GBE. For all existing apartment buildings, the owner may choose to switch from bulk metering to GBE individual metering. The owner bears all costs associated with the above changes. Where such conditions exist that the meters are to be located outside, typically small 4-unit apartments, ganged meter bases must be installed.

#### 4.3.3 Shopping Plaza and Industrial Mall Metering

Each separate store, shop, or industrial unit located in a shopping plaza may be metered individually.

Normally, only one service and one metering location will be provided to a property. Should more than one meter be required, the meters must be grouped in a single meter room on the property. However, consideration may be given to providing multiple services and/or multiple meter rooms on a property under one ownership if there are economic and/or electrical advantages to GBE in doing so. This is typically done only in the cases of large commercial, industrial or apartment/condominium developments where it is not practical for GBE to provide only one service or meter room.

Meter rooms shall be accessible to GBE via an outside lockable door [2m (6'-8") by 0.81m (2'-8")] at grade level. The Customer shall be responsible for supplying a key to GBE. GBE may request that the lock be keyed to GBE specifications. In specific instances and at the sole discretion of GBE, the requirement for an outside door may be waived.

### 4.4 Three Phase Metering Requirements

The following additional conditions apply:



- Meters are to be mounted at a height of 1.7m (5'6")  $\pm$  150mm (6") when measured from finished floor elevation to the center of the meter face/glass. If a metering centre is used, the minimum height allowed for the bottom row of meters is 0.6m (24") and the maximum height allowed for the top row of meters is 1.7m (5'6")  $\pm$  150mm (6") as shown in Appendix A, Drawing "[MS-014](#)". Both dimensions are measured from finished floor elevation to the center of the meter face/glass. It is GBE's preference to have the middle meter locations filled first.
- Metering cabinets, if required, shall be mounted at 1.8m (6')  $\pm$  0.1m (4") from the finished floor elevation to the top of the metering cabinet.
- Any conduits for the exclusive use of GBE shall have no more than three 90°-degree bends. No fittings with removable covers are permitted. At GBE's request the customer or contractor shall install nylon or polypropylene rope pull line in the conduit with an excess of 200mm (8") loop left at each end.
- The Customer's main switch shall be installed so that the top of the switch is 1.8m (6') or less from the finished floor elevation. The Customer's main switch shall permit the sealing and padlocking of the handle in the "open" position and the cover or door in the "closed" position.
- Lighting levels of at least 6 lux (65 footcandles) shall be maintained.
- No water, gas, sewer, or other pipes, communications wire or equipment will be permitted to encroach on the safe working space requirements, as viewed by GBE, of the meter cabinet.
- Meter rooms shall be accessible to GBE via an outside lockable door [2m (6'-8") by 0.81m (2'-8")] at grade level. The Customer shall be responsible for supplying a key to GBE. GBE may request that the lock be keyed to GBE specifications.
- In specific instances and at the sole discretion of GBE, the requirement for an outside door may be waived (i.e., a high-rise apartment building where meter rooms may be required to be located on more than one floor).

Meter mounting devices for use on Commercial/Industrial accounts shall be installed on the load side of the Customer's main switch and located indoors. The Customer is required to supply and install a CSA approved meter socket. Where a neutral connection to the meter socket is required, it shall be not less than #12 AWG copper or equivalent and made directly to the neutral buss.

At the discretion of GBE, the Customer may be allowed to install 347/600V metering outdoors in an approved metering cabinet per GBE metering cabinet specifications listed in section [4.4.1](#).

#### 4.4.1 Three Phase Services without Switchgear

For all three phase services greater than or equal to 225 amps without switchgear:

- Refer to Appendix A Drawings "[MS-016](#) and [MS-017](#)" for equipment requirement and layout details.
- The Customer will supply and install a 900mm x 900mm x 300mm (36" x 36" x 12") metering cabinet (stainless steel NEMA 3R or equivalent if outdoors) after the main disconnect for the service. The metering cabinet shall be complete with a removable backplate and two (2) side-hinged, center-opening doors.



- The Customer will install a full size neutral and isolated terminal block in the metering cabinet.
- The Customer shall supply and install an approved 13-jaw meter base. See [Table 1](#) for GBE approved meter bases.
- The Customer will supply and install a 32mm (1¼") EMT OR PVC conduit from the meter cabinet to the remote 13-jaw meter base.
- The remote 13-jaw meter socket shall be located within 15m (50') of the switchgear metering cabinet.
- The Customer will supply and install a #6 copper bonding conductor with green insulation, and a suitable bonding lug. This bond must be connected to the main service ground point. Within 150 to 200mm (6 to 8") after entering the metering cabinet, connect the bond at the bonding lug and continue a tail long enough to reach the bond connector bar. Routing and connection of this bond is shown in Appendix A, Drawing "[MS-016](#)".
- If bar type current transformers are used, the Customer's Electrician shall supply all necessary lugs and connecting hardware.
- The Customer will supply and install a grounded 120VAC duplex receptacle at the remote meter base, fed from a dedicated 15A single-pole breaker.
- The Customer or contractor will contact GBE Metering Department to arrange a time for GBE staff to pick up the meter cabinet backplate. Allow 10 working days for GBE staff to build and install the metering equipment. GBE staff will deliver the backplate to the site when they are finished.
- At GBE's discretion, the metering equipment supplied by GBE may be installed and wired at the customer site.
- Interval meters will be installed for all new or upgraded services where the monthly average peak demand over a calendar year is forecast to be 50 kW or greater. For any other Customer, please contact GBE for availability.

#### 4.4.2 Three Phase Services with Switchgear

For all three phase services greater than or equal to 225 amps with switchgear:

- Refer to Appendix A Drawings "[MS-018](#) and [MS-019](#)" for equipment requirements and layout details.
- The Customer shall supply and install an approved 13-jaw meter base. See [Table 1](#) for GBE approved meter bases.
- The Customer will supply and install a 32mm (1¼") EMT OR PVC conduit from the switchgear metering cell to the remote 13-jaw meter base.
- The remote 13-jaw meter socket shall be located within 15m (50') of the switchgear metering cell.
- The Customer will supply and install a grounded 120VAC duplex receptacle at the remote meter base, fed from a dedicated 15A single-pole breaker.



- The Customer shall provide at least 2 sets of original switchgear drawings from the manufacturer no less than 6 weeks before the date GBE will energize the service. Any discrepancies between the submitted drawings and the equipment on-site will require re-submittal of new drawings. GBE will not provide comment on 'as-built' switchgear drawings. Any deficiencies caused as a result of not coordinating switchgear drawing approval beforehand must be remedied by the Contractor /Customer at their expense. All switchgear drawings are subject to approval by GBE, and must also include the following manufacturer contact information:
  - a. Switchgear manufacturers contact information and any special instructions
  - b. Project and Job Number
  - c. Complete Shipping Address for the Instrument Transformers
  - d. Full Name and Phone Number(s) of the Contact Person(s)
- GBE will provide the necessary current and potential transformers, and these can be either shipped to the switchgear manufacturer (with reasonable notice) or installed locally by the Customer/Contractor. GBE will not be responsible to install these transformers or perform any bus modifications.
- Interval meters will be installed for all new or upgraded services where the monthly average peak demand over a calendar year is forecast to be 50 kW or greater. For any other Customer, please contact GBE for availability.

#### 4.5 Three Phase Central Metering

At the discretion of GBE, the Customer may be allowed to use a pole-mounted central metering installation for three phase services at 300 kVA, to two or more buildings.

For three phase pole mounted central metering installations, all central metering equipment, including the meter cabinet, will be located on the transformer pole. The pole will be a minimum 40' Class 3 Wood pole, supplied and installed by the Customer.

- Refer to Appendix A Drawings "[MS-016](#) and [MS-022](#)" for equipment requirement and layout details.

For three phase pad mounted central metering installations, the CTs shall be located within the GBE pad mount transformer. The meter cabinet containing the meter and potential transformers (if required for 347/600V service) shall be located on 6"x 6" pressure treated post or a freestanding meter cabinet structure. If potential transformers are not required (ie. 120/208V service) a remote 13-jaw meter base shall be installed on the GBE pad mount transformer.

- Refer to Appendix A Drawings "[MS-016](#), [MS-020](#), and [MS-021](#)" for equipment requirement and layout details.

When required, the Customer will supply and install a NEMA 3R 900mm x 900mm x 300mm (36" x 36" x 12") metering cabinet with a three-point latch and handle. The metering cabinet shall be complete with a removable backplate, and two (2) side hinged, center-opening doors.

- Bottom entry only for all conduits enter the metering cabinet.



- For three phase pole mounted central metering, the Customer will supply and install a continuous 32mm (1¼") EMT OR PVC conduit from the meter cabinet up the pole to a point 0.76m (30") above the neutral wire, complete with weather head.
- For 347/600V three phase pad mounted central metering, the Customer will supply and install a continuous 32mm (1¼") EMT OR PVC conduit from the meter cabinet underground into the transformer vault at a minimum depth of 0.76m (30") below finished grade.
- The Customer will supply and install a #6 copper bonding conductor with green insulation, and a suitable bonding lug. This bond must be connected to the main service ground point or ground rod. Within 150 to 200mm (6 to 8") after entering
- The Customer or contractor will contact GBE Metering Department when all conduit work is completed, meter cabinet and 120VAC duplex receptacle installed. Allow 10 working days for GBE staff to build and install the metering equipment.
- At GBE's discretion, the metering equipment supplied by GBE may be installed and wired at the customer site.
- Interval meters will be installed for all new or upgraded services where the monthly average peak demand over a calendar year is forecast to be 50 kW or greater.

The Economic Evaluation Model would apply to GBE's costs.

## 4.6 Primary Metering

Primary metering may be permitted at the discretion of GBE. The cost of the primary metering transformer unit (PMU) or primary metering transformers (PMT) shall be included in the Economic Evaluation Formula. A deposit payable in full to GBE is required before GBE orders such equipment. GBE will retain ownership of primary metering equipment.

Each primary metered service is reviewed thoroughly and on an individual basis. The Customer and/or its agent shall submit to GBE all required switchgear and electrical single line drawings in a timely manner to allow for GBE's reviews and approvals. Drawing submissions in electronic format must be in either AutoCAD ".dwg" or ".pdf" format.

Primary metering potential transformers in Customer-owned switchgear shall be installed in a manner that permits fuse and/or PT replacement while the service is energized via:

- a. PT's and fuses mounted on a tilt-out drawer or slide-out tray, or
- b. Fuses mounted on a slide-out tray with PTs in a separate compartment, allowing for all the following positions:
  - i. Connected
  - ii. Isolated
  - iii. Grounded

Provisions for padlocking to be provided for the connected and grounded positions of the PT drawer/tray.

The PT/fuse compartment(s) must be fully barriered from remaining compartments to permit servicing of the PT's or fuses while the remainder of the switchgear is energized.



All clearances shall be per the Electrical Safety Code. Any filed modifications shall be subject to the Electrical Safety Authority (ESA) Inspection and Canadian Standards Associations (CSA) field evaluation.

Please contact GBE early in the design stage to begin the review as additional standards and requirements for primary metering may apply. Please note that GBE does not stock either PMU's or PMT's and that this equipment typically has long lead times.

#### 4.7 Interval Metering

Interval meters will be installed for all new or upgraded services where the monthly average peak demand over a calendar year is forecast to be 50 kW or greater. For any other Customer, please contact GBE for availability.

#### 4.8 Metering Pulse Outputs

Several of GBE's customers have requested access to GBE's real time meter data to supply inputs to the customer's energy management systems.

For most three phase services greater than 200 Amps, GBE will provide Customer access to certain KYZ metering pulse output(s) after completing a site review and quotation for the Customer. The Customer will be responsible for all costs associated with supplying access to the metering pulse outputs. The "GBE Metering Pulse Output(s) Access Agreement" in [Appendix B](#) must also be completed and sent to GBE for approval. Contact GBE's Metering Department for further details



## Appendix A: GrandBridge Energy Metering Standard Drawings: MS-001 to MS-023

<u>Drawing #</u>		<u>Page</u>
<a href="#">MS-001</a>	Multiple Unit Metering Identification Detail	20
<a href="#">MS-002</a>	New Underground Service, Single-Phase 120/240V, Meter Base Located Outside – Equipment Layout	21
<a href="#">MS-003</a>	Existing Overhead Service, Single Phase 120/240V Meter Base Relocation (Inside to Outside) – Equipment Layout	22
<a href="#">MS-004</a>	Existing Underground Service, Single Phase 120/240V Meter Base Relocation (Inside to Outside) – Equipment Layout	23
<a href="#">MS-005</a>	Multiple Unit Metering, up to and Including 200 AMPS Per Metered Sub-Service, 120/240V, Ganged Meter Bases, Underground Service Equipment Layout	24
<a href="#">MS-006</a>	Multiple Unit Metering, up to and Including 200 A per Metered Sub-Service, 120/240V, Ganged Meter Bases, Overhead Service Equipment Layout	25
<a href="#">MS-007</a>	Multiple Unit Metering, up to and Including 200 AMPS Per Metered Sub-Service, 120/240V, Ganged Meter Bases, Underground or Overhead Service – Load Side Wiring Configuration Specifications	26
<a href="#">MS-008</a>	400 Amp, Single-Phase, 120/240V Underground Service with Transformer Type Combination Meter Base Enclosure Equipment Layout	27
<a href="#">MS-009</a>	400 Amp, Single Phase, 120/240V Overhead Service With Transformer-Rated Combination Meter Base Enclosure Equipment Layout	28
<a href="#">MS-010</a>	400 Amp, Single Phase, 120/240V With Free Standing Transformer-Rated Combination Meter Base Enclosure - Equipment Layout	29
<a href="#">MS-011</a>	Central Metered Pad Mount, Single Phase 200-600 Amp, 120/240V service, Equipment Layout	30
<a href="#">MS-012</a>	Central-Metered Service, 200 or 400 A, 120/240V – Equipment Layout	31
<a href="#">MS-013</a>	Multiple Unit Metering, Below 225A - 120/240V, 120/208V and 347/600V Without Meter Centre – Equipment Layout	32
<a href="#">MS-014</a>	Multiple Unit Metering, Below 225A - 120/240V, 120/208V and 347/600V With Meter Centre – Equipment Layout	33
<a href="#">MS-015</a>	Three Phase Metering Below 225A – 120/208V and 347/600V without	34



Meter Centre – Equipment Layout

<a href="#">MS-016</a>	Bonding, Three Phase Metering Cabinets, Electronic Metering - Equipment Layout	35
<a href="#">MS-017</a>	Meter Cabinet – Standard Mounting Layout for Three Phase, Four-Wire Secondary Services 225 Amps and Above Without Switchgear	36
<a href="#">MS-018</a>	Meter Cabinet – Standard Mounting Layout for Three Phase, Four-Wire Secondary Services with Low-Voltage Switchgear	37
<a href="#">MS-019</a>	Multiple Unit Metering, Combination of Services Below and Above 225A - 120/240V, 120/208V and 347/600V Equipment Layout	38
<a href="#">MS-020</a>	Central Metered Pad mount, Three Phase, 200-1200 Amp, 120/208V Service - Equipment Layout	39
<a href="#">MS-021</a>	Central Metered Pad mount, Three Phase, 200-1200 Amp, 347/600V Service - Equipment Layout	40
<a href="#">MS-022</a>	Central Metered Service, 120/208V AND 347/600V, 225 – 800 Amp Equipment Layout	41
<a href="#">MS-023</a>	Primary Metering Unit Base Assembly Upright Pole Mount Configuration	42



MS-001 Multiple Unit Metering Identification Detail

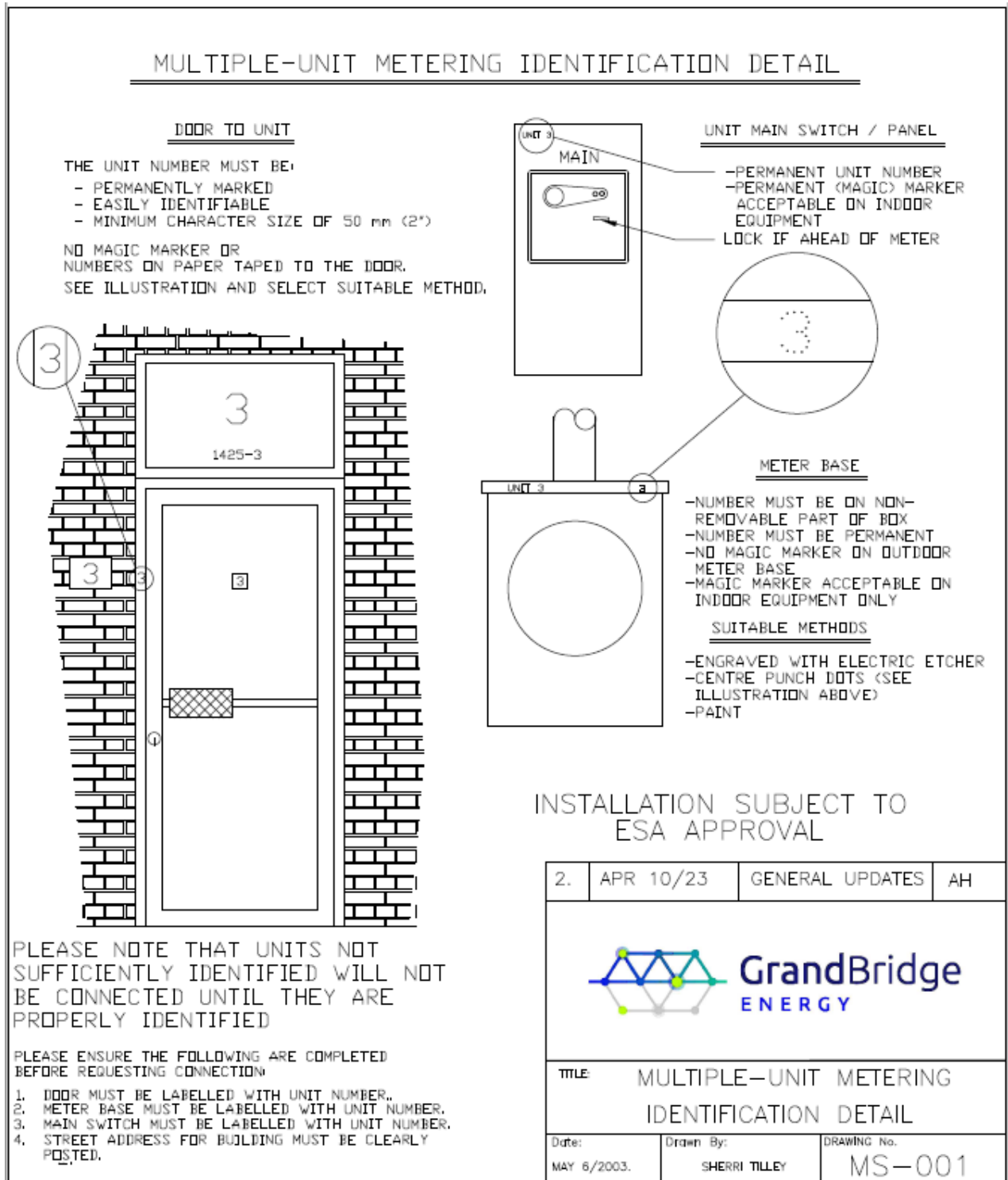

**GRANDBRIDGE ENERGY METERING SPECIFICATIONS**

*MS-002 New Underground Service, Single-Phase 120/240V, Meter Base Located Outside – Equipment Layout*

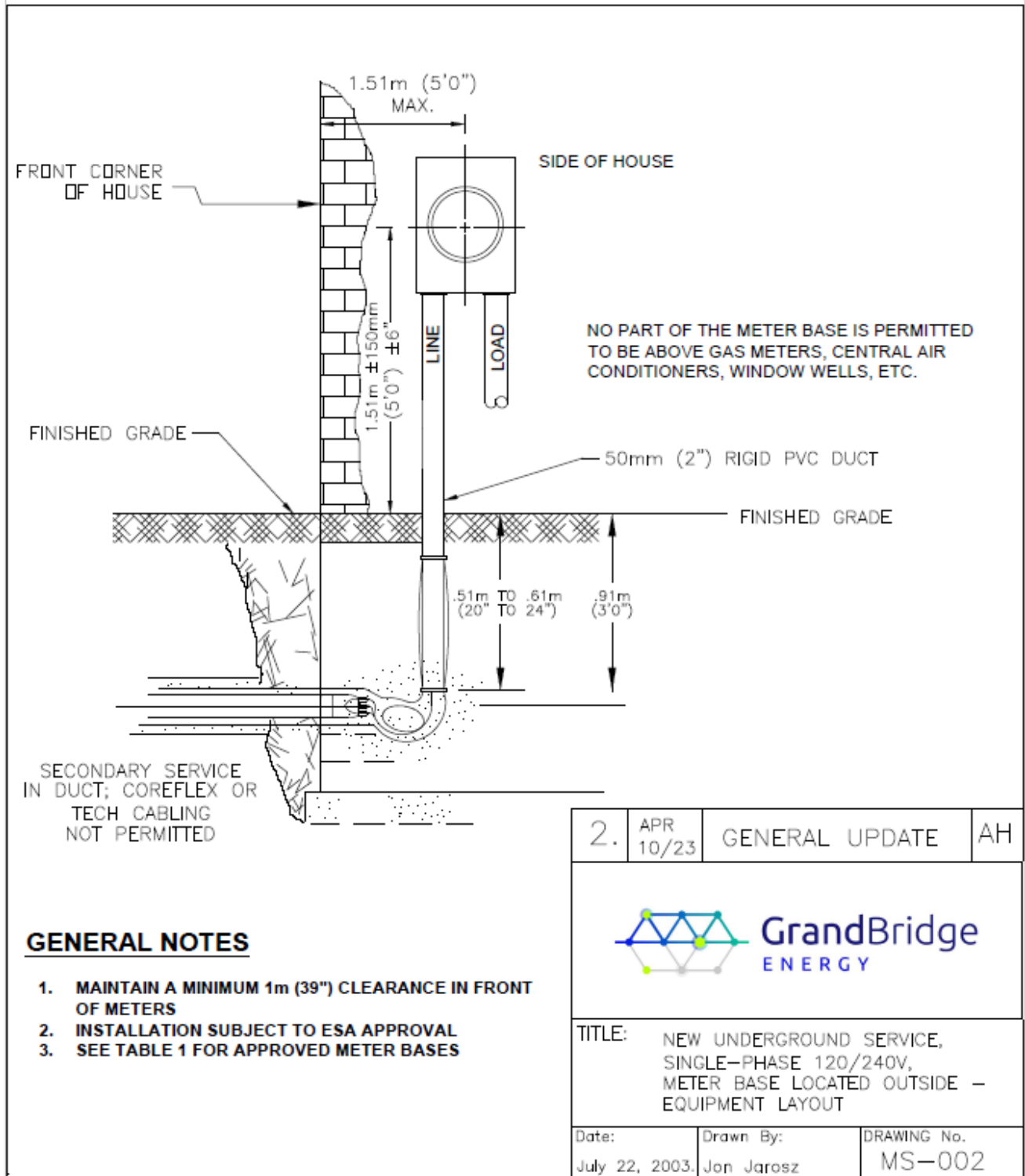

MS-003 New Overhead Service, Single-Phase 120/240V Meter Base Located Outside

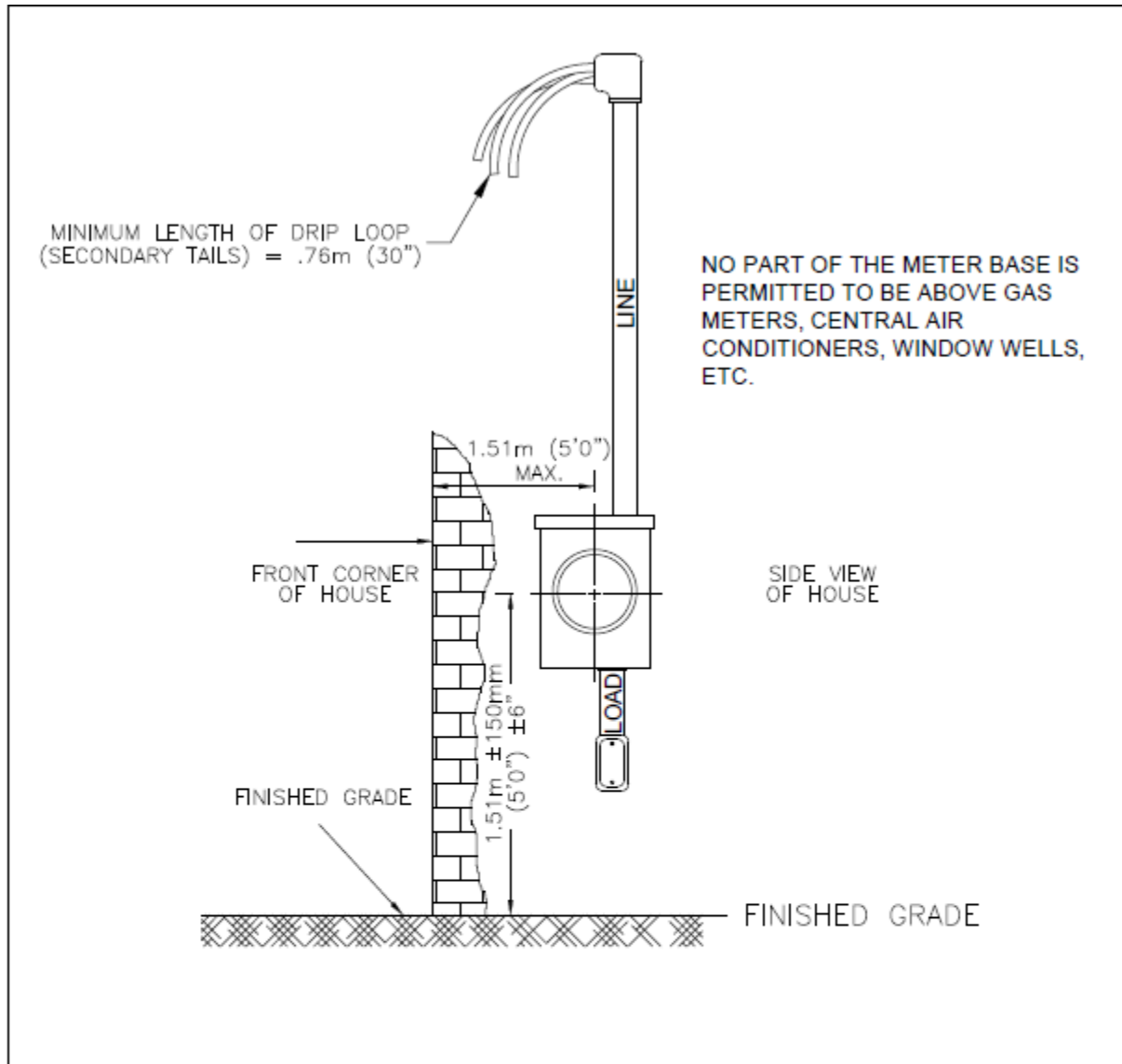

**GENERAL NOTES**

1. MAINTAIN A MINIMUM 1m (39") CLEARANCE IN FRONT OF METER CABINET
2. POINT-OF-ATTACHMENT SUBJECT TO ESA APPROVAL
3. INSTALLATION SUBJECT TO ESA APPROVAL
4. POINT-OF-ATTACHMENT & STACK MUST BE INSTALLED SO THAT INCOMING OVERHEAD SERVICE WIRE, AS WELL AS DRIP LOOP DO NOT CONTACT ANY PART OF THE HOUSE/STRUCTURE.
5. SEE TABLE ONE FOR APPROVED METER BASES

2.	APR 10/23	GENERAL UPDATE	AH
----	-----------	----------------	----



TITLE: NEW OVERHEAD SERVICE, SINGLE-PHASE 120/240V METER BASE LOCATED OUTSIDE - EQUIPMENT LAYOUT

Date: JUNE 6, 2003.	Drawn By: Jon Jarosz	DRAWING No. MS-003
------------------------	-------------------------	-----------------------



**GRANDBRIDGE ENERGY METERING SPECIFICATIONS**

*MS-004 Existing Overhead/Underground Service, Single-Phase 120/240V Meter Base Relocation (Inside to Outside)  
- Equipment Layout*

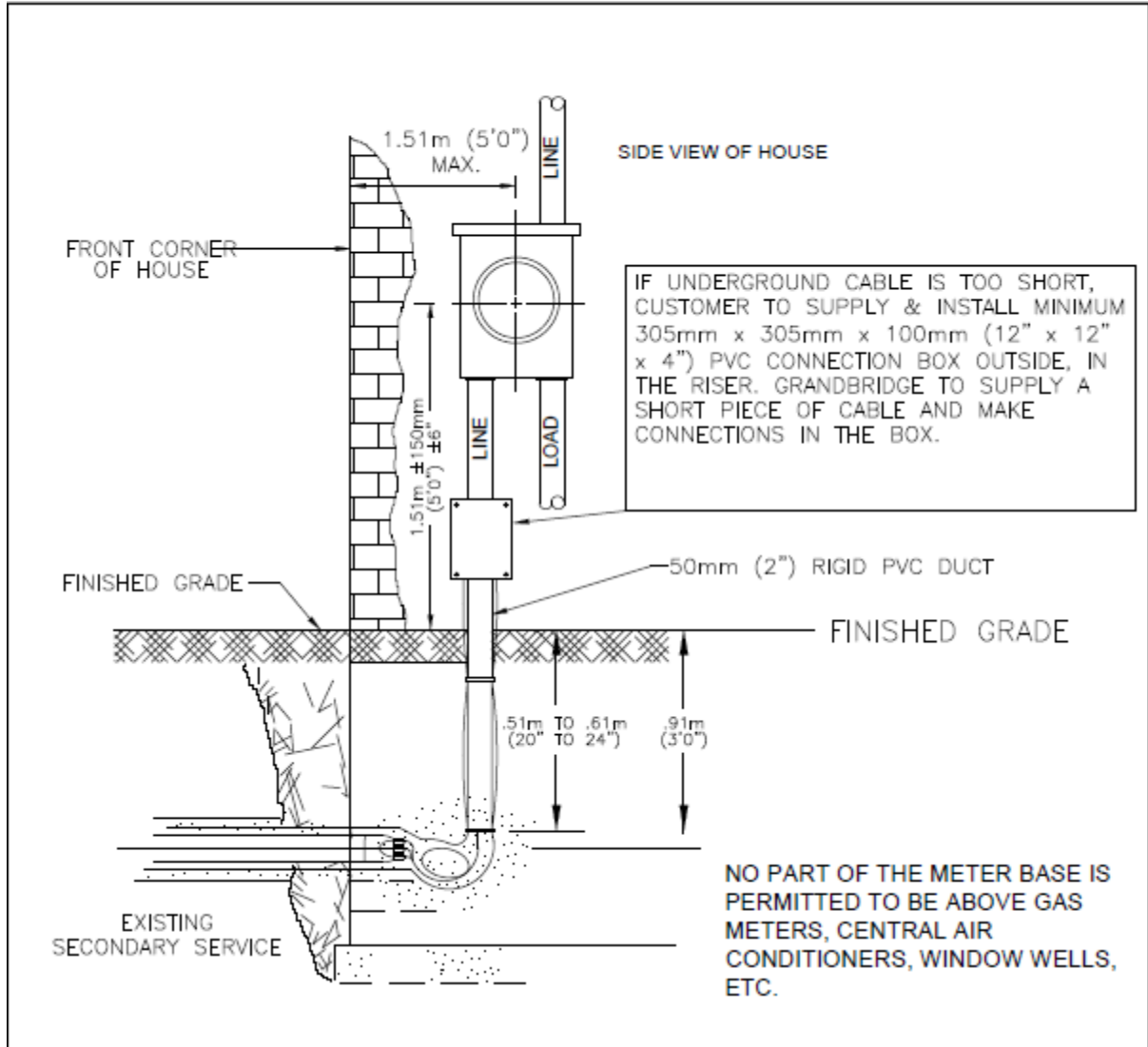

**GENERAL NOTES**

1. MAINTAIN A MINIMUM 1m (39") CLEARANCE IN FRONT OF METER CABINET
2. INSTALLATION SUBJECT TO ESA APPROVAL
3. SEE TABLE 1 FOR APPROVED METER BASES

1.	APR 10/23	GENERAL UPDATE	AH
----	-----------	----------------	----



TITLE: EXISTING **OVERHEAD/UNDERGROUND** SERVICE, SINGLE-PHASE 120/240V METER BASE RELOCATION (INSIDE TO OUTSIDE) – EQUIPMENT LAYOUT

Date:	Drawn By:	DRAWING No.
JUNE 6, 2003.	Jon Jarosz	MS-004



MS-005 Multiple Unit Metering, Up to And Including 200 Amps Per Metered Sub-service, 120/240V, Ganged Meter bases, Underground Service - Equipment Layout

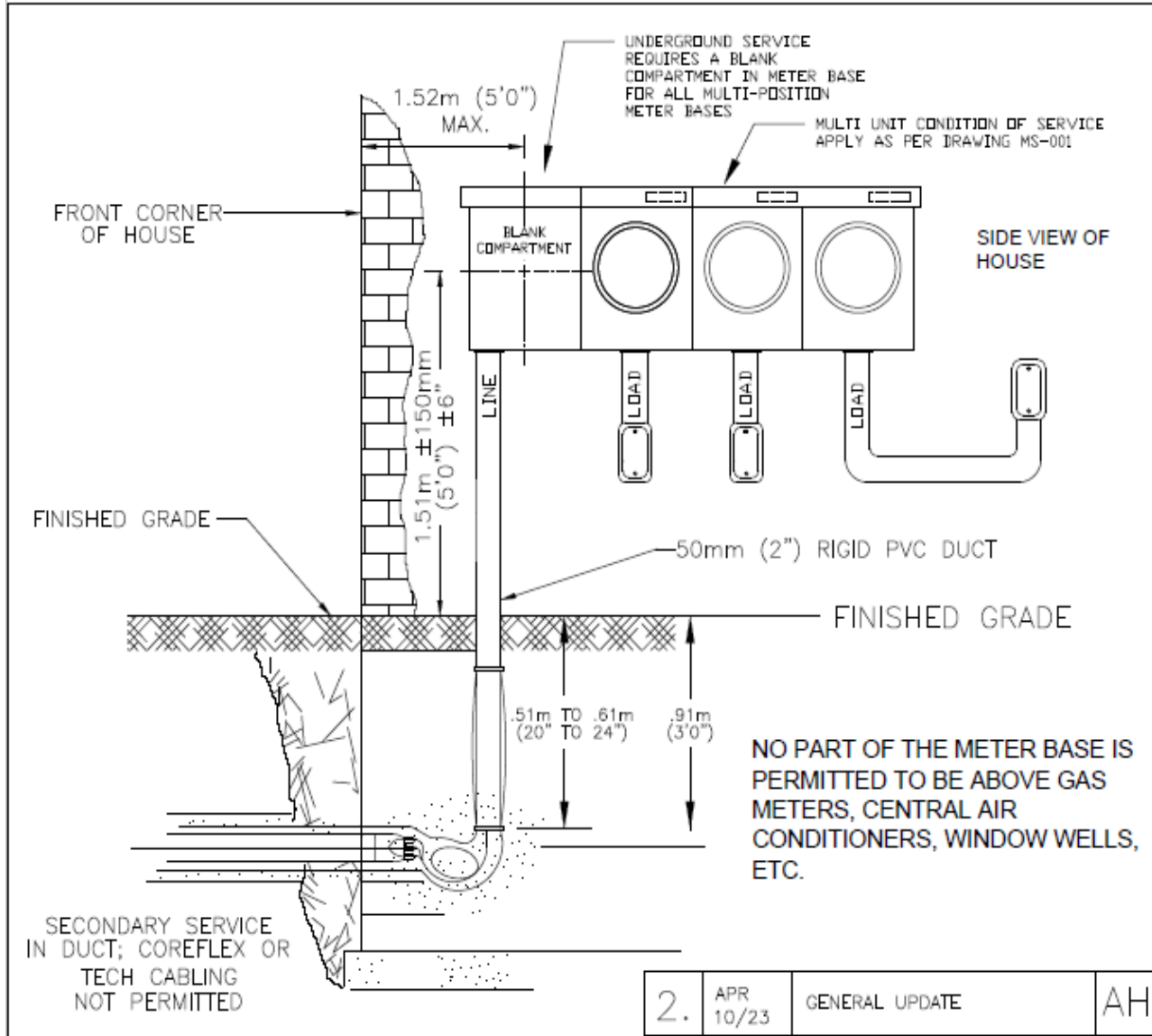

**GENERAL NOTES**

1. MAINTAIN A MINIMUM 1m (39") CLEARANCE IN FRONT OF METERS
2. BLANK COMPARTMENT IN METER BASE REQUIRED FOR ALL MULTI-POSITION METER BASES
3. INSTALLATION SUBJECT TO ESA APPROVAL
4. REFER TO MS-007 FOR CORRECT LOAD SIDE WIRE CONFIGURATION
5. SEE TABLE 1 FOR APPROVED METER BASES

2.	APR 10/23	GENERAL UPDATE	AH
----	-----------	----------------	----



TITLE: MULTIPLE UNIT METERING, UP TO AND INCLUDING 200 AMPS PER METERED SUB-SERVICE, 120/240V, GANGED METER BASES, UNDERGROUND SERVICE - EQUIPMENT LAYOUT

Date: SEPT. 23, 2003.	Drawn By: Jon Jarosz	DRAWING No. MS-005
--------------------------	-------------------------	-----------------------



*MS-006 Multiple Unit Metering, Up to And Including 200 Amps Per Metered Sub-Service, 120/240V, Ganged Meter Bases, Overhead Service – Equipment Layout*

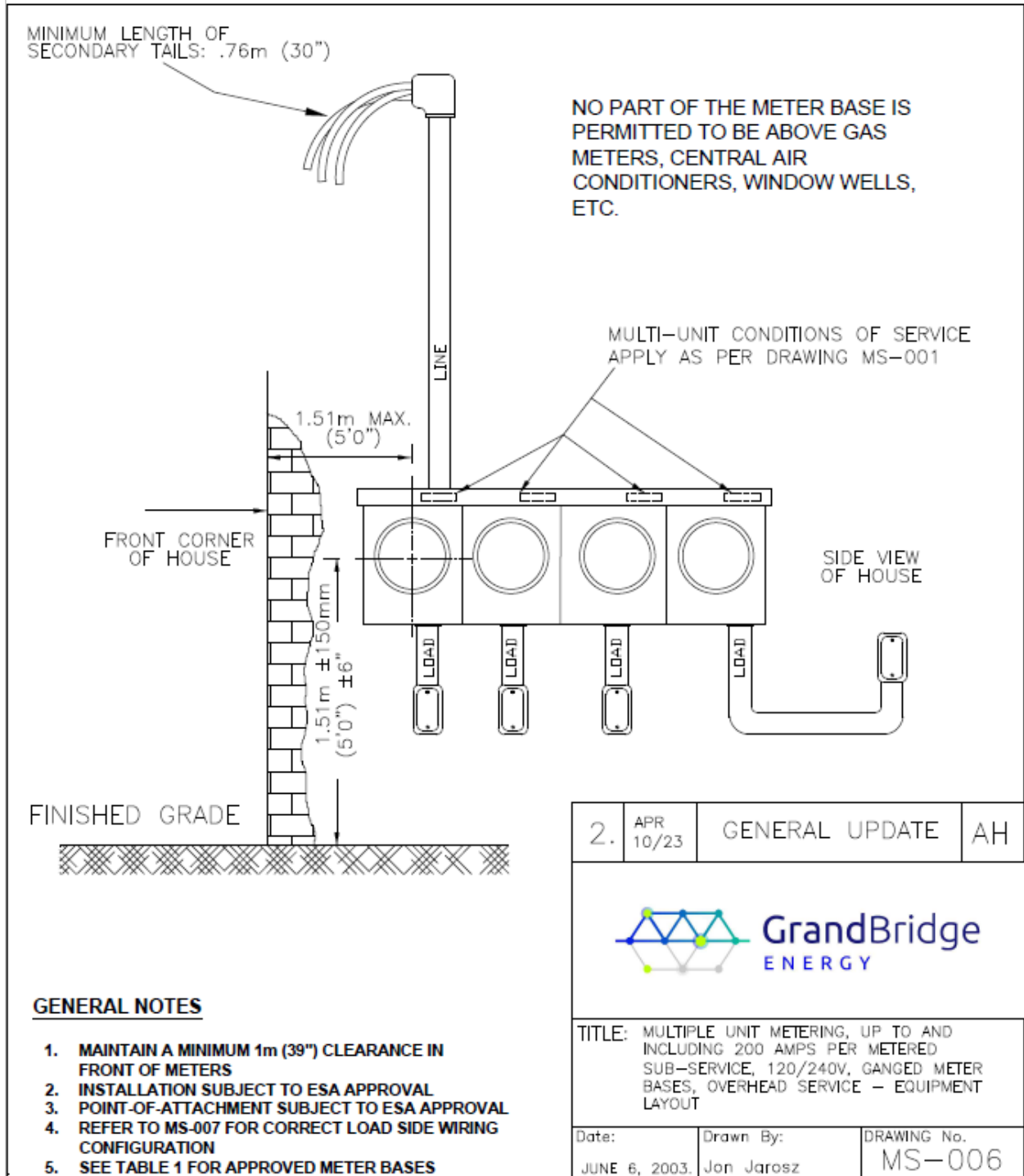

*MS-007 Multiple Unit Metering, Up to And Including 200 Amps Per Metered Sub-Service – Load Side Wiring Configuration Specifications*

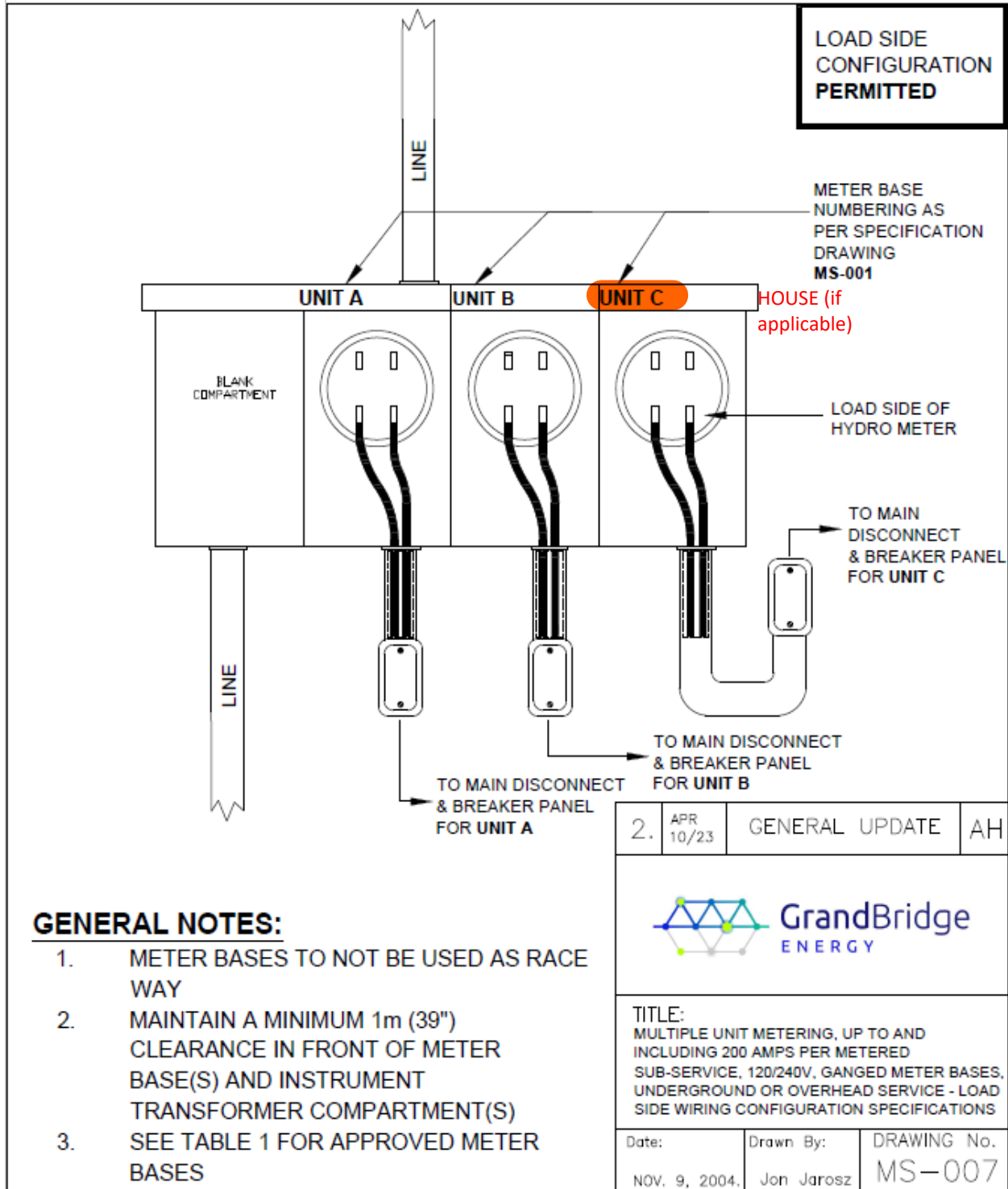

**GENERAL NOTES:**

1. METER BASES TO NOT BE USED AS RACE WAY
2. MAINTAIN A MINIMUM 1m (39") CLEARANCE IN FRONT OF METER BASE(S) AND INSTRUMENT TRANSFORMER COMPARTMENT(S)
3. SEE TABLE 1 FOR APPROVED METER BASES



MS-008 400 Amp, Single-Phase, 120/240V Underground Service with Transformer Type Combination Meter Base Enclosure – Equipment Layout

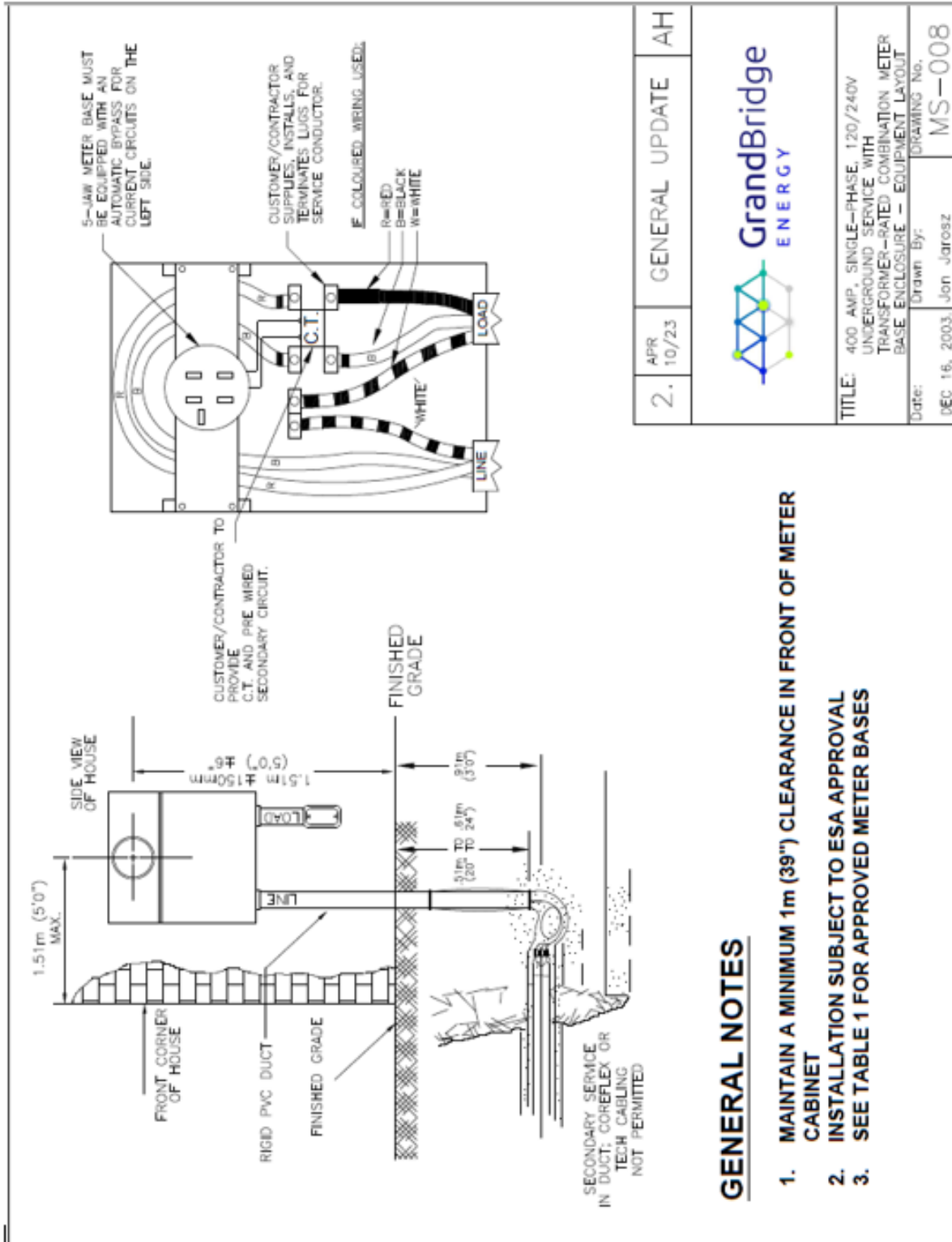

**GENERAL NOTES**

1. MAINTAIN A MINIMUM 1m (39") CLEARANCE IN FRONT OF METER CABINET
2. INSTALLATION SUBJECT TO ESA APPROVAL
3. SEE TABLE 1 FOR APPROVED METER BASES



MS-009 400 Amp, Single Phase, 120/240V Overhead Service with Transformer Type Combination Meter Base Enclosure – Equipment Layout

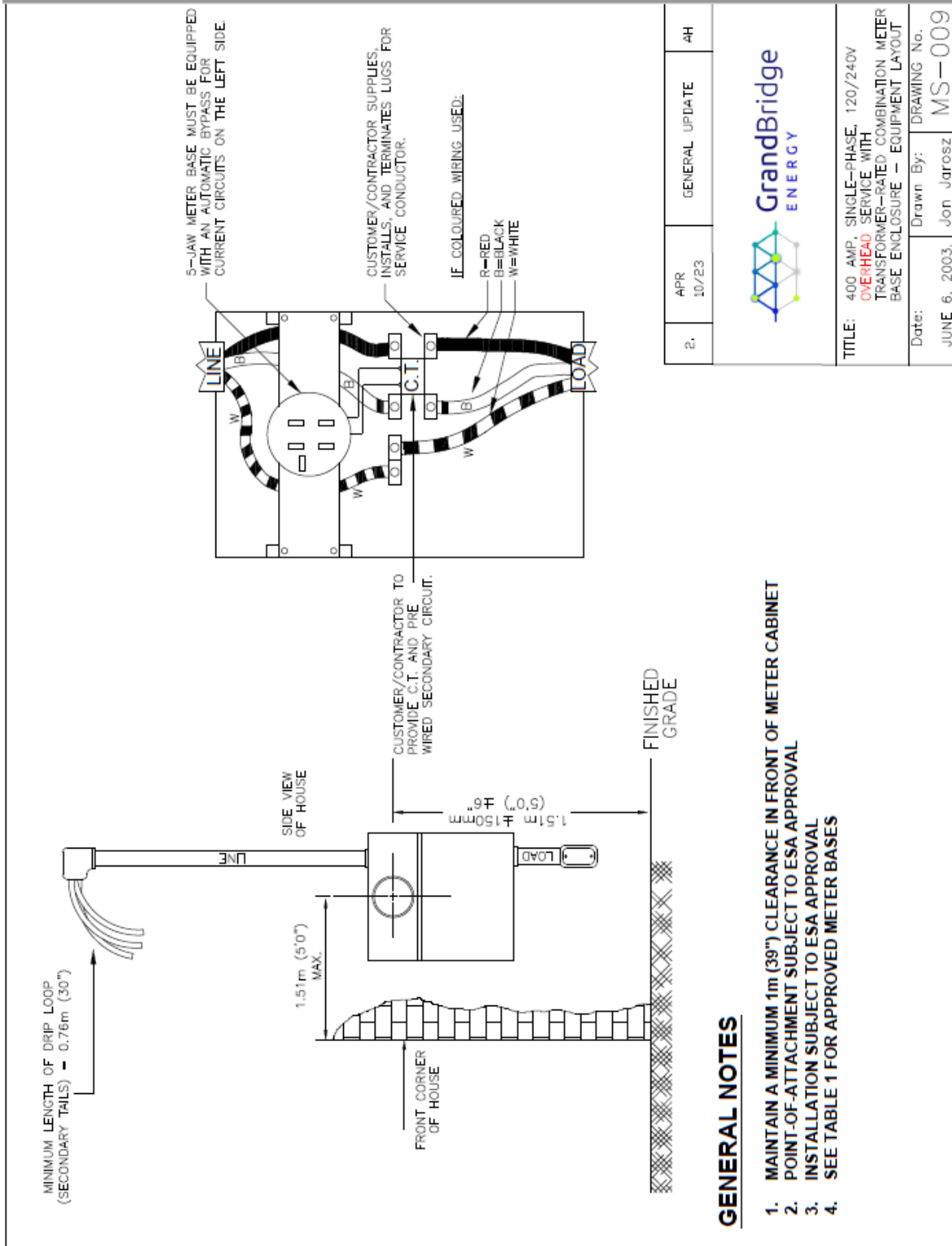

**GENERAL NOTES**

1. MAINTAIN A MINIMUM 1m (39") CLEARANCE IN FRONT OF METER CABINET
2. POINT-OF-ATTACHMENT SUBJECT TO ESA APPROVAL
3. INSTALLATION SUBJECT TO ESA APPROVAL
4. SEE TABLE 1 FOR APPROVED METER BASES

2.	APR 10/23	GENERAL UPDATE	4H
TITLE: 400 AMP, SINGLE-PHASE, 120/240V OVERHEAD SERVICE WITH TRANSFORMER-RATED COMBINATION METER BASE ENCLOSURE – EQUIPMENT LAYOUT			
Date:	Drawn By:	DRAWING No.	
JUNE 6, 2003.	Jan Jarosz	MS-009	



MS-010 400 Amp, Single-Phase, 120/240V with Free Standing Transformer-Type Combination Meter Base Enclosure – Equipment Layout

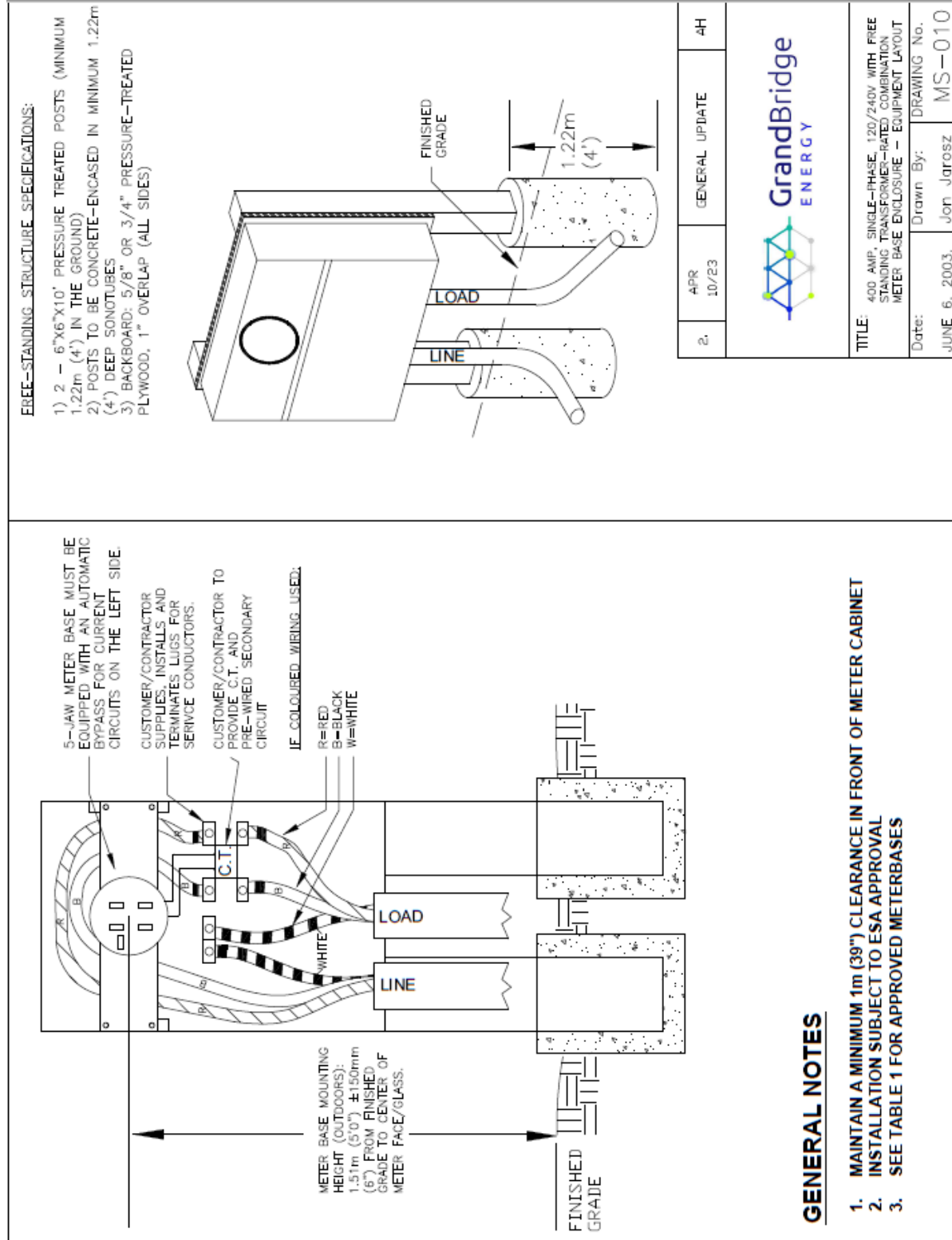

MS-011 Central Metered Pad Mount Single-Phase, 200-600 Amp, 120/240V Service – Equipment Layout

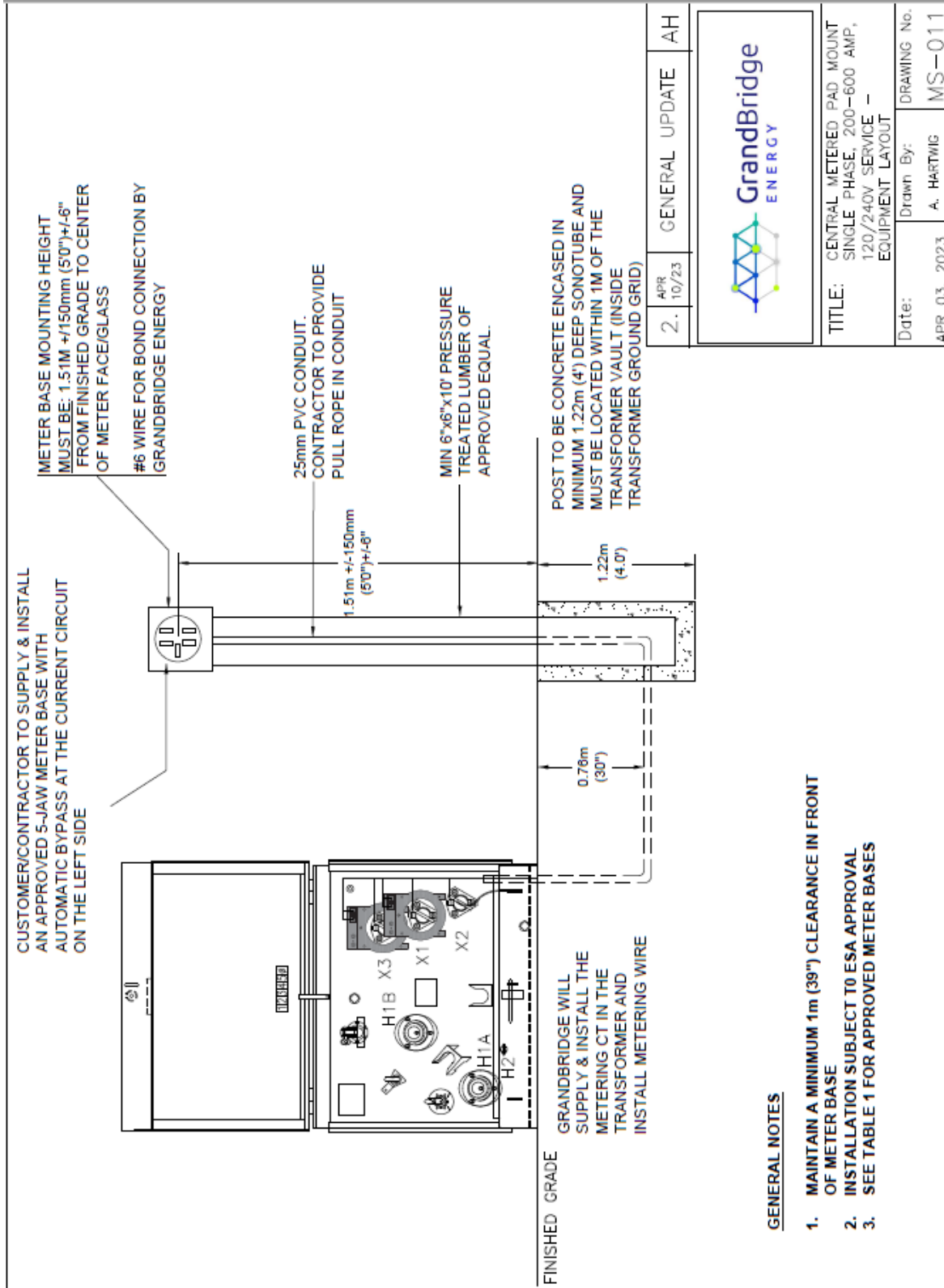

APR 10/23	GENERAL UPDATE	AH
TITLE: CENTRAL METERED PAD MOUNT SINGLE PHASE, 200-600 AMP, 120/240V SERVICE - EQUIPMENT LAYOUT		
Date:	Drawn By:	DRAWING No.
APR 03, 2023	A. HARTWIG	MS-011



MS-012 Central Metered Service, 200 Amp or 400 Amp, 120/240V – Equipment Layout

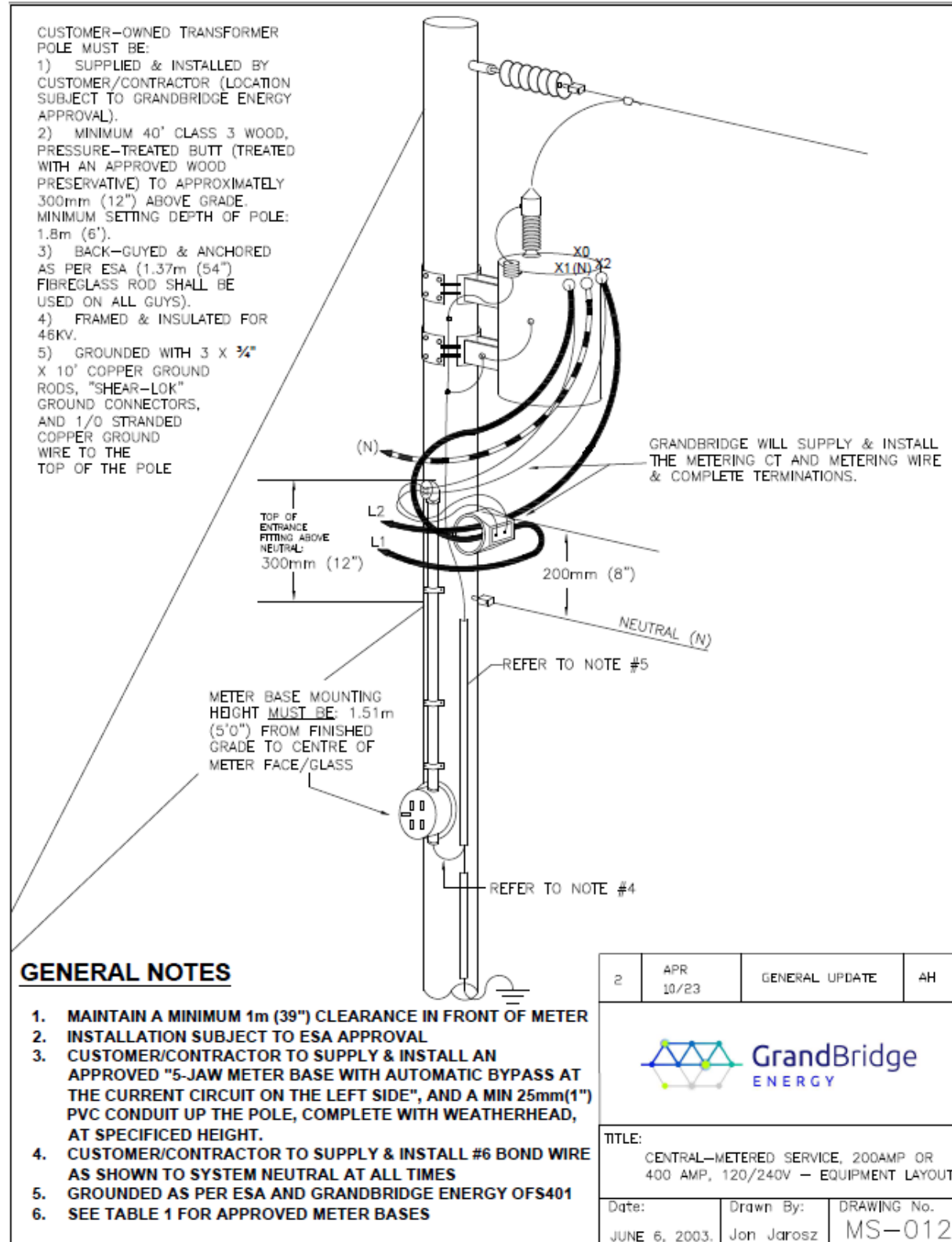

MS-013 Multiple Unit Metering, Below 225 Amps – 120/240V, 120/208V, and 347/600V Without Meter Centre – Equipment Layout

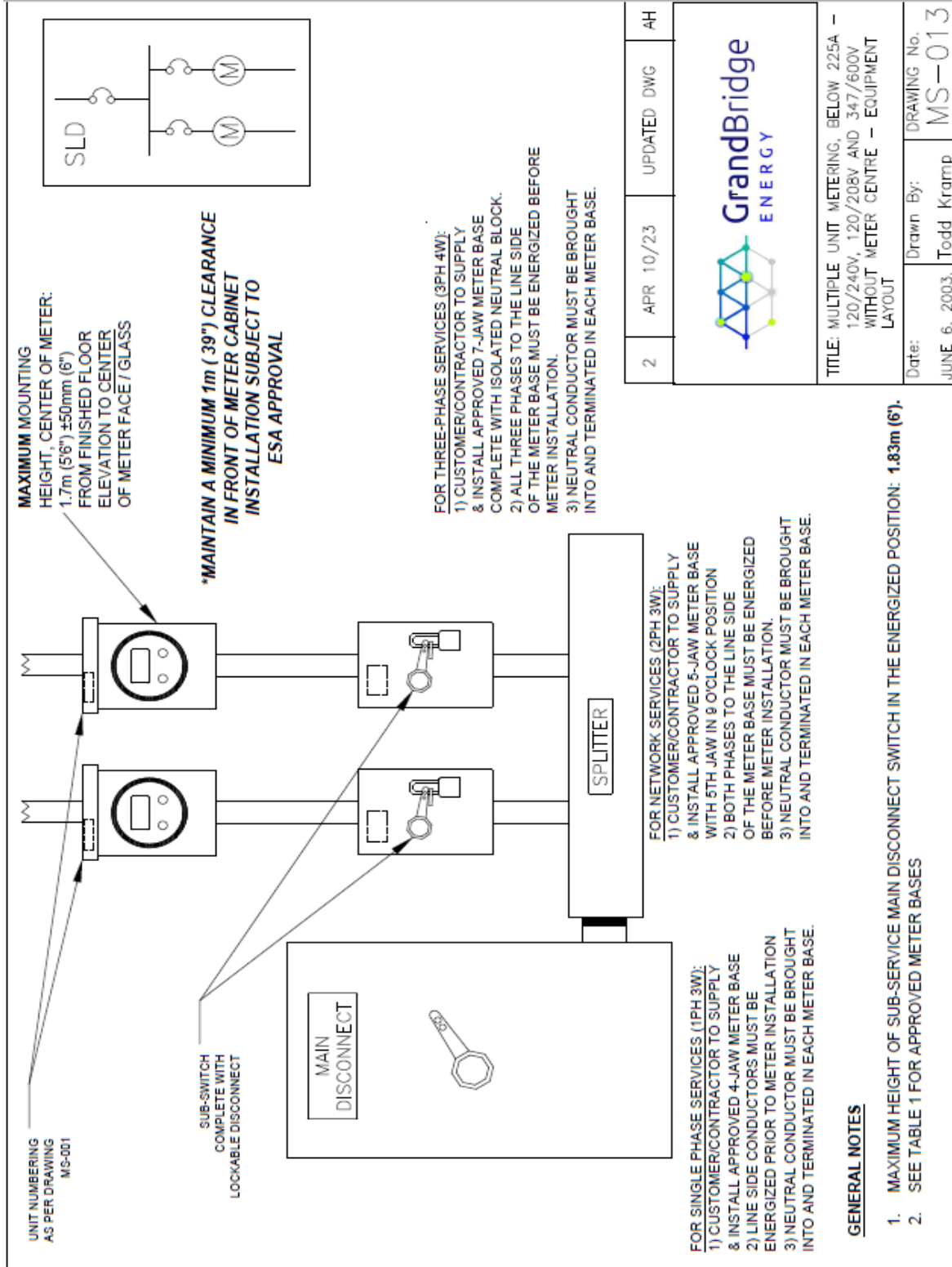

MS-014 Multiple Unit Metering, Below 225 Amps – 120/240V, 120/208V, and 347/600V with Meter Centre – Equipment Layout

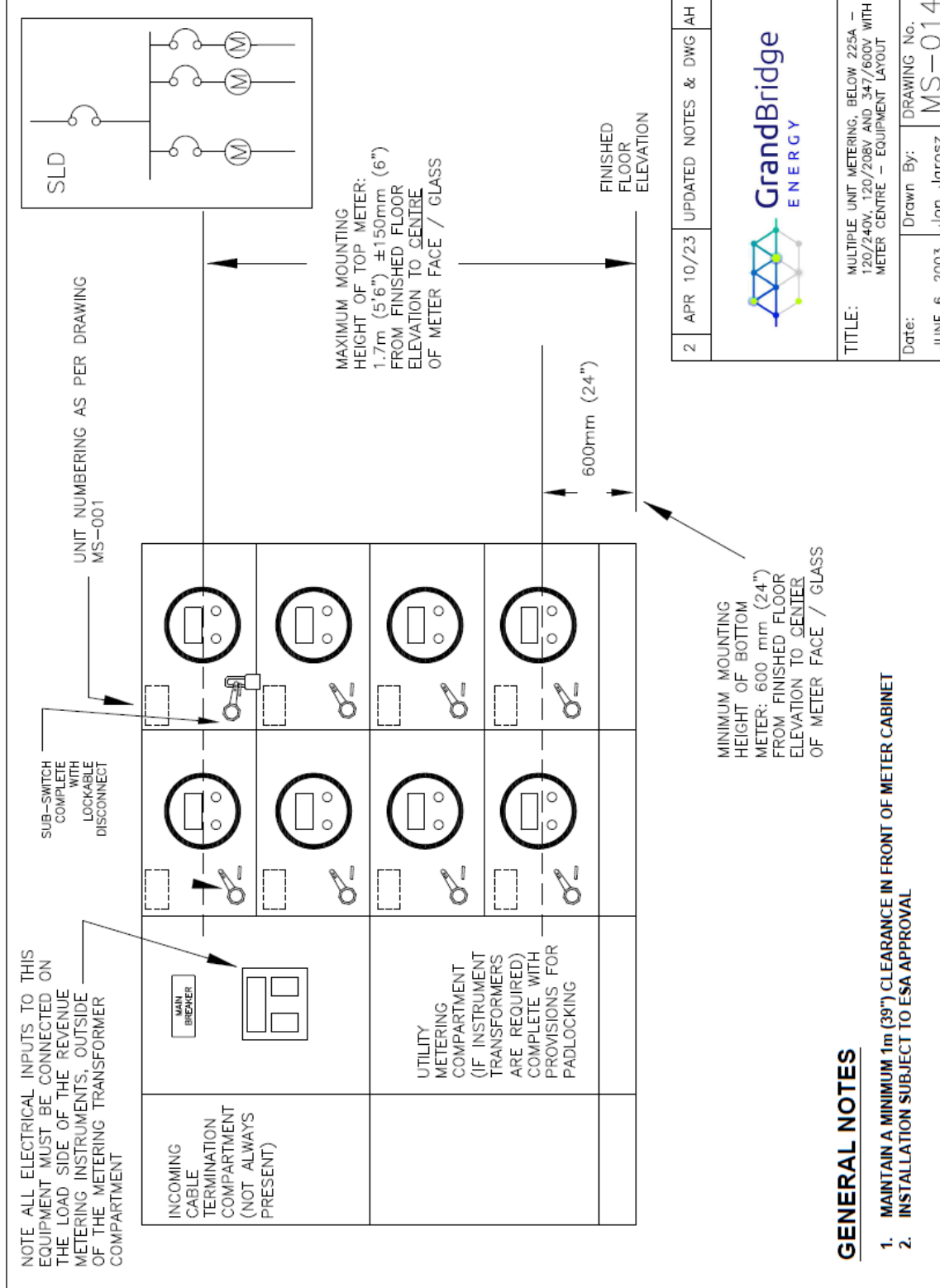

MS-015 Three Phase Metering, Below 225 Amps- 120/208V and 347/600V without Meter Centre – Indoor Equipment Layout

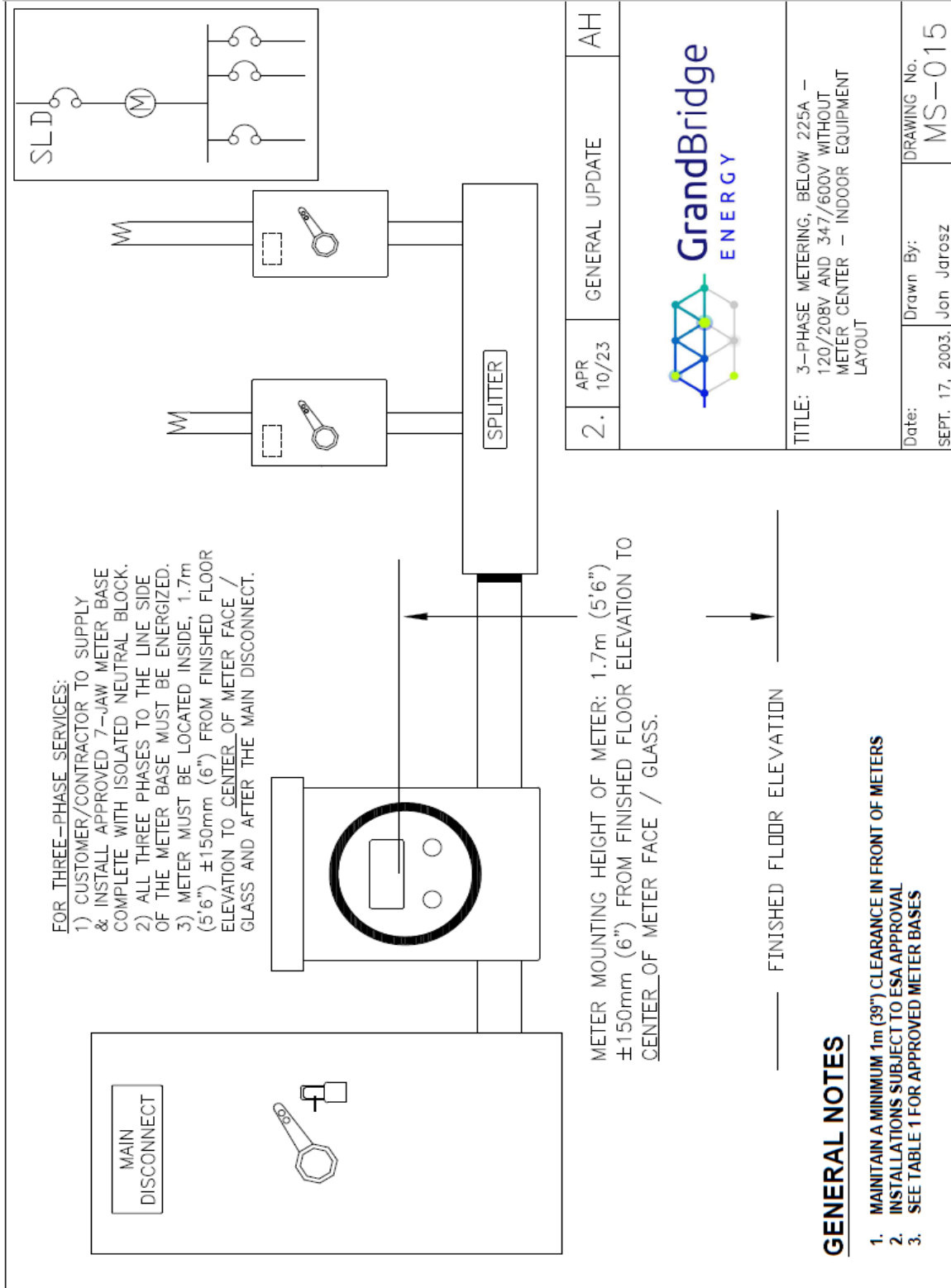

2.	APR 10/23	GENERAL UPDATE	AH
TITLE: 3-PHASE METERING, BELOW 225A – 120/208V AND 347/600V WITHOUT METER CENTER – INDOOR EQUIPMENT LAYOUT			
Date:	SEPT. 17, 2003.	Drawn By:	Jon Jarosz
		DRAWING No.	MS-015



MS-016 Bonding, Three Phase Metering Cabinets, Electronic Metering – Equipment Layout

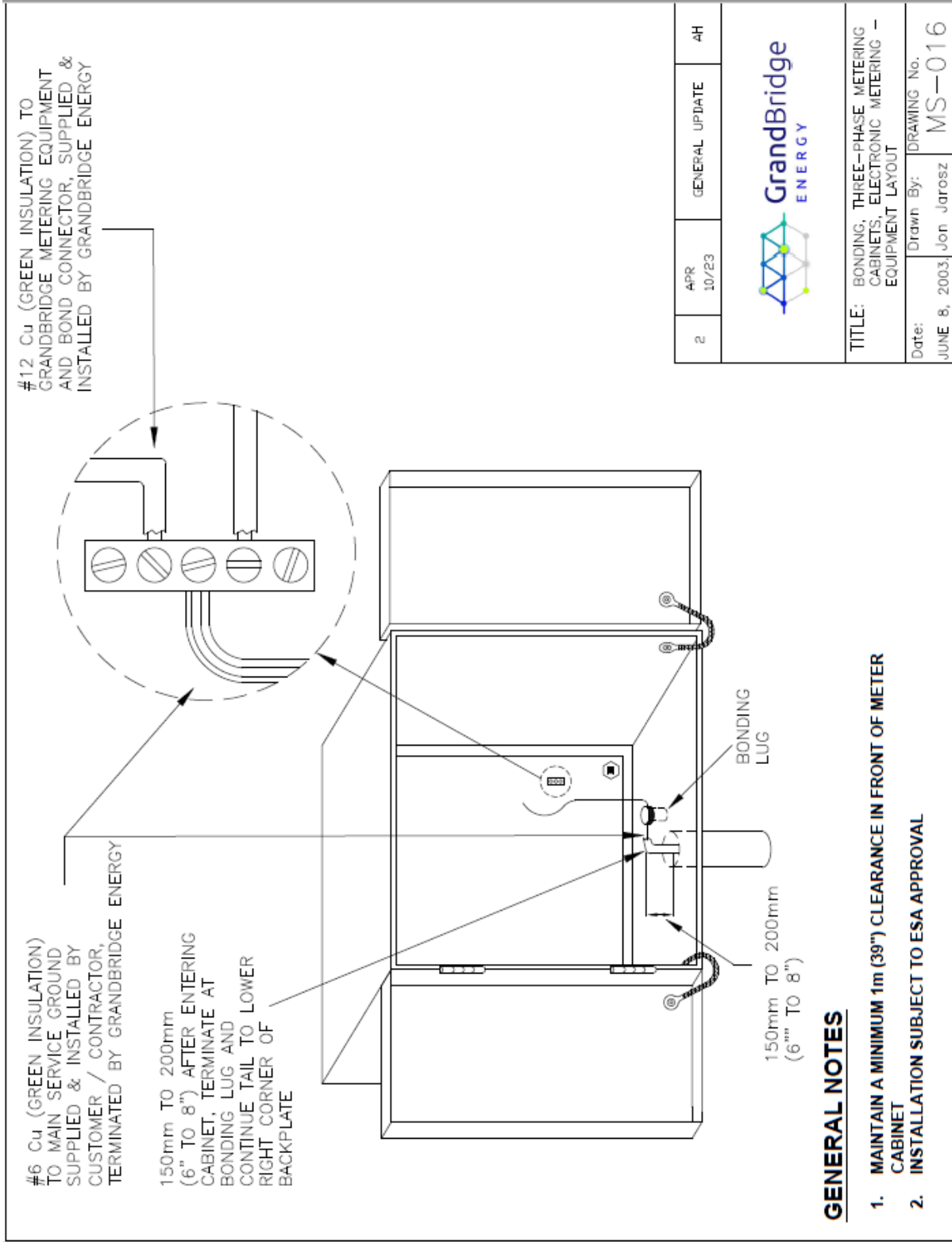

**GENERAL NOTES**

1. MAINTAIN A MINIMUM 1m (39") CLEARANCE IN FRONT OF METER CABINET
2. INSTALLATION SUBJECT TO ESA APPROVAL

2	APR 10/23	GENERAL UPDATE	AH
			
TITLE: BONDING, THREE-PHASE METERING CABINETS, ELECTRONIC METERING – EQUIPMENT LAYOUT			
Date: JUNE 8, 2003		Drawn By: Jon Jarosz	
		DRAWING No. MS-016	

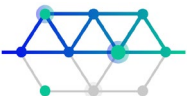







MS-020 Central Metered Pad Mount Three Phase, 200-1200 Amp, 120/208V Service – Equipment Layout

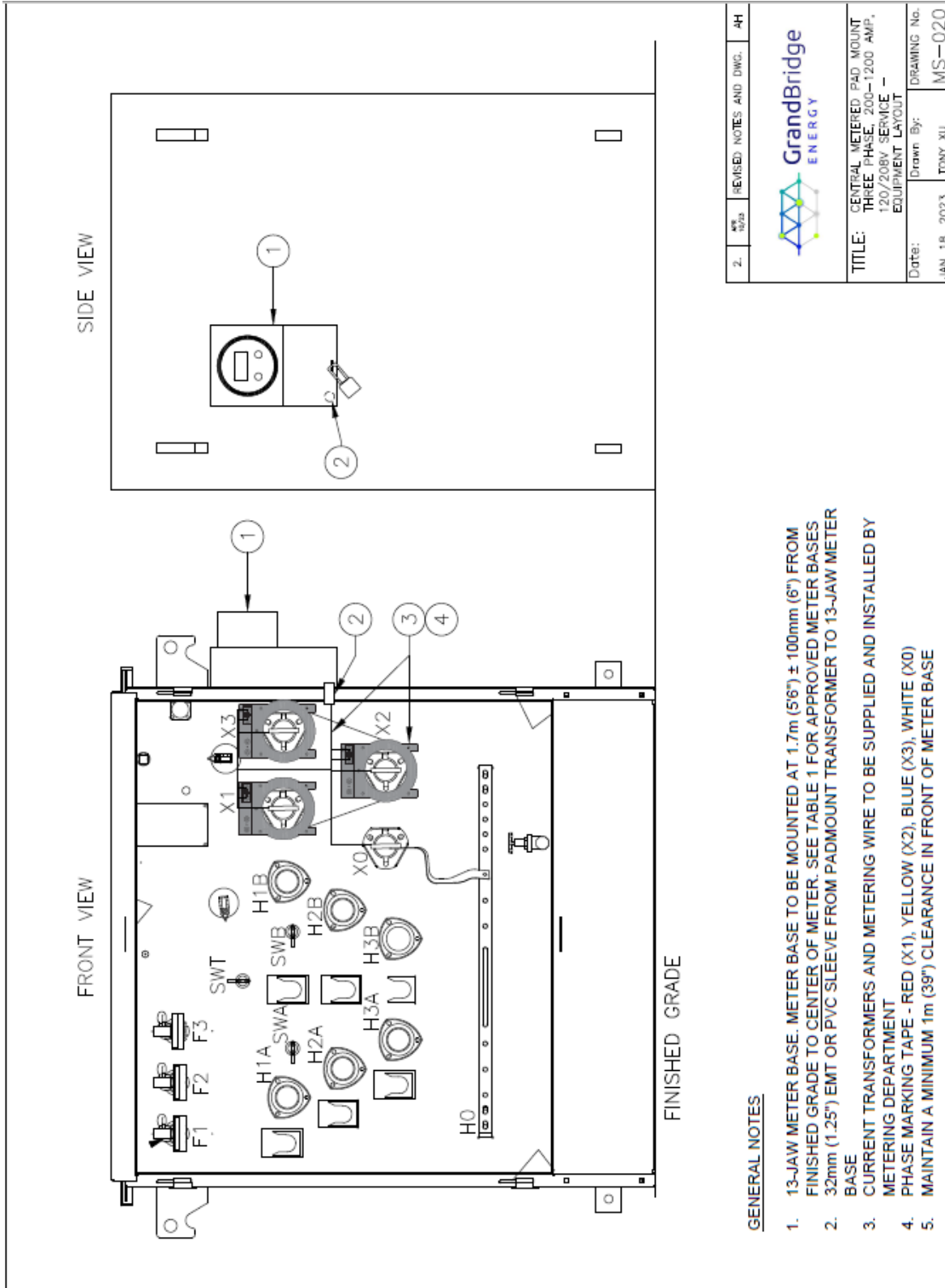

GENERAL NOTES

1. 13-JAW METER BASE. METER BASE TO BE MOUNTED AT 1.7m (5'6") ± 100mm (6") FROM FINISHED GRADE TO CENTER OF METER. SEE TABLE 1 FOR APPROVED METER BASES
2. 32mm (1.25") EMT OR PVC SLEEVE FROM PADMOUNT TRANSFORMER TO 13-JAW METER BASE
3. CURRENT TRANSFORMERS AND METERING WIRE TO BE SUPPLIED AND INSTALLED BY METERING DEPARTMENT
4. PHASE MARKING TAPE - RED (X1), YELLOW (X2), BLUE (X3), WHITE (X0)
5. MAINTAIN A MINIMUM 1m (39") CLEARANCE IN FRONT OF METER BASE

2.	REVISED NOTES AND DWG.	AH
TITLE: CENTRAL METERED PAD MOUNT THREE PHASE, 200-1200 AMP, 120/208V SERVICE - EQUIPMENT LAYOUT		
Date:	Drawn By:	DRAWING No.
JAN 18, 2023	TONY XU	MS-020



MS-021 Central Metered Pad Mount Three Phase, 200-1200 Amp, 347/600V Service – Equipment Layout

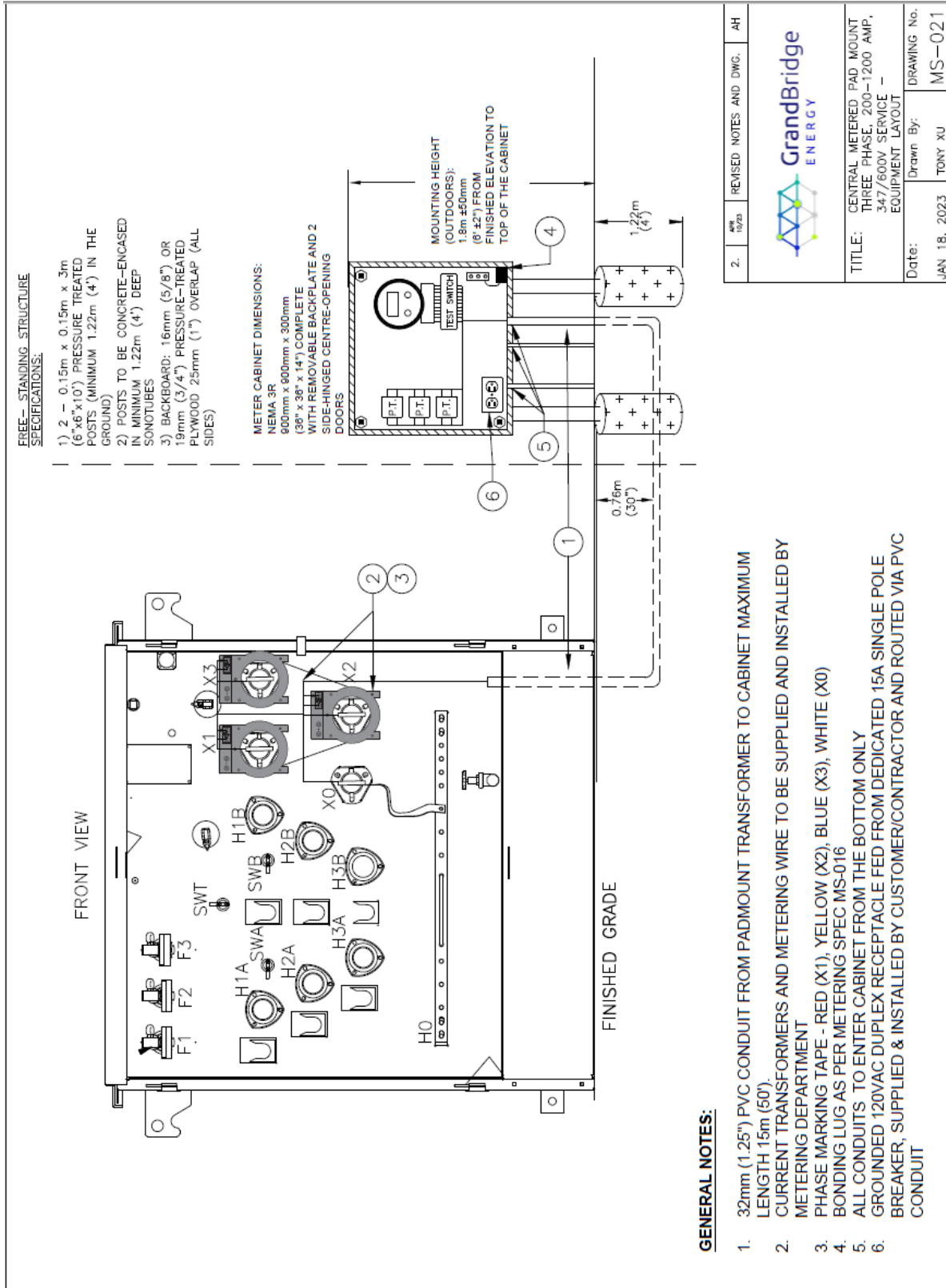



2.	REVISED NOTES AND DWG.	AH
TITLE: CENTRAL METERED PAD MOUNT THREE PHASE, 200-1200 AMP, 347/600V SERVICE - EQUIPMENT LAYOUT		
Date:	Drawn By:	DRAWING No.
JAN 18, 2023	TONY XU	MS-021



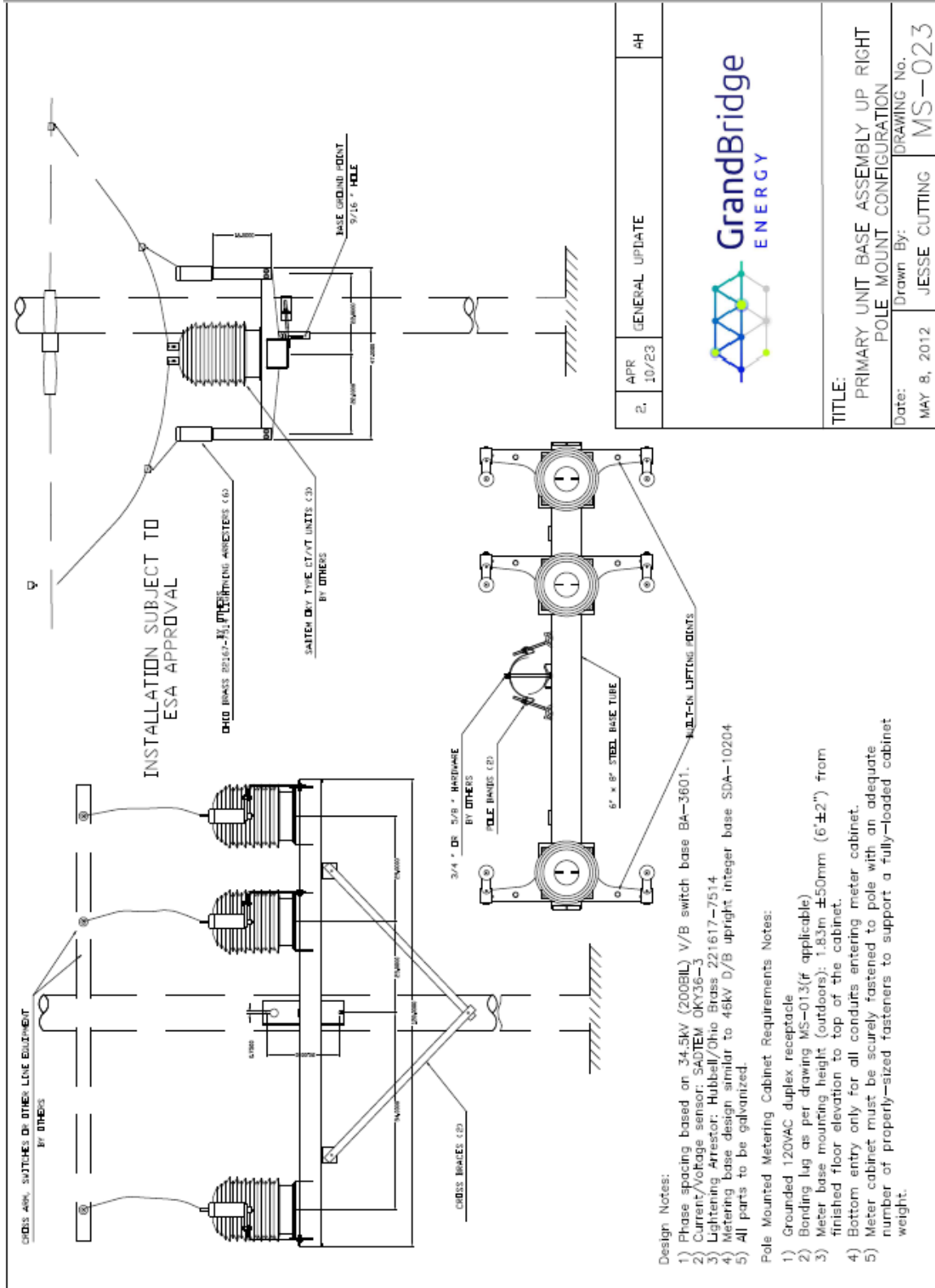

MS-023 Primary Metering Unit Assembly, Up-Right, Pole Mount Configuration



2.	APR 10/23	GENERAL UPDATE	AH
			
<b>TITLE:</b> PRIMARY UNIT BASE ASSEMBLY UP RIGHT POLE MOUNT CONFIGURATION			
Date:	MAY 8, 2012	Drawn By: JESSE CUTTING	DRAWING No. MS-023



## Appendix B: GrandBridge Energy Metering Pulse Output(s) Access Agreement

This agreement between

GrandBridge Energy Inc.  
150 Savannah Oaks Drive  
Brantford, ON.  
N3T 5N8

Hereafter referred to as GBE,

and

Consumer's Business Name: \_\_\_\_\_

Address: \_\_\_\_\_

City: \_\_\_\_\_ Province/State: \_\_\_\_\_

Postal/Zip Code: \_\_\_\_\_

Carrying out business at:

Consumer's Service Address: \_\_\_\_\_

City: \_\_\_\_\_ Province: Ontario

Postal Code: \_\_\_\_\_

GBE. Account #: \_\_\_\_\_

Carrying out business as:

Business Name: \_\_\_\_\_

Hereafter referred to as the Consumer,

shall define the relationship between GBE and the Consumer and it's Assigned Third Party, if applicable, with respect to provision of isolated, KYZ metering pulse output(s). For the purposes of this agreement, the term 'Assigned Third Party' is meant to include Retailers.

Pursuant to Section 11.1 (Provision of Current Usage Data to Retailers) and Section 11.2 (Provision of Current Usage Data to Consumers) of the Retail Settlement Code, GBE agrees to provide isolated, KYZ metering pulse output(s) from GBE's meter at the Consumer's above-noted service address under the following conditions:



- The Consumer or Assigned Third Party must request a quotation for the total cost of installing equipment to provide the necessary KYZ pulses. This will include but is not limited to; isolation relays to electrically protect GBE metering equipment, labour, truck time, terminal strips, isolation relay cover and separate pulse output enclosure. Also, the Consumer or Assigned Third Party must supply an Electrical Safety Authority (ESA) inspected 120 VAC duplex receptacles within the existing meter cabinet. This receptacle should be on a separate, fused circuit to avoid tripping due to other devices on the line. Once this quotation is done and accepted by the Consumer or Assigned Third Party, a purchase order must be issued before GBE will schedule the work. Please allow 6-8 weeks after receipt of the purchase order for work to be completed due to labour scheduling and material lead times.
- GBE will supply either: Watt-hour, Watt-hour/VA-hour, or Watt-hour/VAR-hour KYZ pulses depending on the outputs available from the GBE meter already installed or to be installed at the Consumer's metering installation.
- If it is deemed that GBE's metering installation is somehow compromised by any unforeseen event or circumstances not present at this time, the Consumer's/ Assigned Third Party's access to the isolated, KYZ metering pulse outputs may be suspended by GBE.
- The Consumer shall pay the reasonable cost of any software, hardware or other services required for the Consumer/Assigned Third Party to obtain isolated, KYZ metering pulse output access to the GBE meter.
- The Consumer shall bear any cost incurred by GBE to correct problems caused by the Consumer's/Assigned Third Party's access to the isolated, KYZ metering pulse output(s). This includes but is not limited to; trouble calls to repair/maintain the isolated, metering pulse output(s) connections and equipment, replacement of any parts/equipment required to sustain the metering pulse output(s), and additional labour required to re-connect and test the isolated, metering pulse output(s) during a required meter change.
- If the Consumer assigns his or her right to isolated, KYZ metering pulse output(s) access to any Assigned Third Party, the Consumer shall remain responsible for the action of the Assigned Third Party. Also, the Consumer must supply the following contact information regarding the Assigned Third Party to GBE in the space below:  
(If applicable, please complete. For more than one Assigned Third Party please attach additional information for each to the end of this Agreement.)

Assigned Third Party Information

Business Name: \_\_\_\_\_

Contact Name: \_\_\_\_\_

Address: \_\_\_\_\_

City: \_\_\_\_\_ Province/State: \_\_\_\_\_

Postal/Zip Code: \_\_\_\_\_ Retailer Licence #: \_\_\_\_\_

Phone: \_\_\_\_\_

Fax: \_\_\_\_\_



E-mail: \_\_\_\_\_

- If the Consumer wishes to withdraw the right from any Assigned Third Party, it must do so in writing to GBE so that any other affected parties can be notified.
- The data obtained by the Consumer or its Assigned Third Party via the isolated, KYZ metering pulse output(s) from the meter is to be considered raw and without any additional validation, estimation or editing applied to it by GBE. As such, it is expected that this data may vary on occasion from that supplied by GBE’s billing system, or any other source of settlement-ready interval metering data. If a discrepancy occurs between any data presented to the Consumer and that presented by GBE’s actual billing, GBE’s actual billing must be used as correct values. GBE does not assume any liability for any damages or losses that may occur as a result of further use of raw interval data.

This agreement shall be applicable to all successors and assigns and shall not be re-assigned without written notification of GBE.

Contact with the Consumer regarding this agreement will be with the person(s) listed below with respect to this interval metering installation for the purposes of read-only access. The Primary Contact will be responsible for maintaining the communication link at the interval meter location.

Consumer Contact Information

(Required) Primary Contact Name: \_\_\_\_\_

Address: \_\_\_\_\_

City: \_\_\_\_\_ Province/State: \_\_\_\_\_

Postal/Zip Code: \_\_\_\_\_

Phone: \_\_\_\_\_

Fax: \_\_\_\_\_

E-mail: \_\_\_\_\_

(Optional) Alternate Contact Name: \_\_\_\_\_

Address: \_\_\_\_\_

City: \_\_\_\_\_ Province/State: \_\_\_\_\_

Postal/Zip Code: \_\_\_\_\_ Phone: \_\_\_\_\_

Fax: \_\_\_\_\_ E-mail: \_\_\_\_\_



Contact with GBE will be with the undersigned.

For the Consumer, I have the authority to bind the company.

Signature: \_\_\_\_\_

Name: \_\_\_\_\_

Position: \_\_\_\_\_

Date: \_\_\_\_\_

Address: \_\_\_\_\_

City: \_\_\_\_\_ Province/State: \_\_\_\_\_

Postal/Zip Code: \_\_\_\_\_

Phone: \_\_\_\_\_

Fax: \_\_\_\_\_

E-mail: \_\_\_\_\_

For GrandBridge Energy Inc.

Signature: \_\_\_\_\_

Name: Settlement Analyst  
Phone: 519.621.3530 x2356

Date: \_\_\_\_\_

Once the completed and signed Agreement is mailed or faxed to GBE, we will supply a detailed summary of the metering information required to enable the Consumer/Assigned Third Party to have isolated access to this metering installation.

Please keep a completed and signed Agreement for your records, a copy of the final Agreement signed back by GBE will then be returned to the Consumer/Assigned Third Party.



Table 1: GrandBridge Energy Inc. Approved Meter Bases

SINGLE POSITION METER BASE SELECTION TABLE				
SERVICE VOLTAGE (PHASE/WIRE)	SERVICE AMPERAGE	SOCKET TYPE	ANSI FORM	APPROVED MODELS
120/240V (1PH / 3W) <b>UNDERGROUND SERVICE</b>	<=200A	4-JAW (NOTE 4)	2S	<b>MICRO ELECTRIC:</b> BS2-TCV, BS2-TV <b>HYDEL:</b> EK400RO, EK400TO <b>EATON:</b> LM2, LU2
120/240V (1PH / 3W) <b>OVERHEAD SERVICE</b>	<=200A	4 JAW (NOTE 4)	2S	ANY 200A CSA APPROVED MODEL
120/240V (1PH / 3W)	400A	5-JAW (NOTE 1,2,4)	3S	<b>HYDEL:</b> CT4-3 <b>EATON:</b> TCC5-3
120/240V CENTRAL METERED SERVICE (1PH / 3W)	<=600A	5-JAW (NOTE 1,2,4)	3S	<b>MICRO ELECTRIC:</b> CL5-V <b>HYDEL:</b> CTS409PW <b>EATON:</b> TCC5-0
120/208V NETWORK SERVICE (2PH / 3W)	<=200A	5-JAW (NOTE 1,4)	12S	ANY CSA APPROVED MODEL
120/208V (3PH / 4W)	<=200A	7 JAW (NOTE 4)	16S	ANY CSA APPROVED MODEL
347/600V (3PH / 4W)	<=200A	7 JAW (NOTE 4)	16S	ANY CSA APPROVED MODEL
120/208V OR 347/600V (3PH / 4W)	>200A	13 JAW (NOTE 4)	9S	<b>MICRO ELECTRIC:</b> CT113 <b>HYDEL:</b> CTS130PW <b>EATON:</b> TSU13

MULTI-POSITION METER BASE SELECTION TABLE				
SERVICE VOLTAGE (PHASE/WIRE)	SERVICE AMPERAGE	SOCKET TYPE	ANSI FORM	APPROVED MODELS
120/240V (1PH / 3W) <b>UNDERGROUND SERVICE</b>	200A OR 400A MAIN with 200A PER POSITION	4 JAW (NOTES 3,4,5)	2S	<b>MICRO ELECTRIC:</b> BDA2, BDC2, BDC3, BS42, BS43 <b>HYDEL:</b> SDC220PW, SDC320PW, SDC420PW, SDC520PW, HC22R, HC23R, HC24R, HC42R, HC43R, HC45R <b>EATON:</b> 2KN1, 2K2, 3KN1 3K2, 2K4, 3K4
120/240V (1PH / 3W) <b>OVERHEAD SERVICE</b>	<=200A PER POSITION	4 JAW (NOTE 4)	2S	ANY 200A CSA APPROVED MODEL

**NOTES:**

1. 5<sup>TH</sup> JAW REQUIRED IN THE 9 O’CLOCK POSITION
2. BY-PASS DEVICE REQUIRED ON LEFT SIDE JAWS
3. UNDERGROUND SERVICES REQUIRE A BLANK CONNECTION COMPARTMENT
4. INSOLATED NEUTRAL KIT REQUIRED
5. SECONDARY CONDUCTOR MUST BE SIZED BASED ON COMBINED METER LOADING AND SHALL BE APPROVED BY GBE ENGINEERING PRIOR TO INSTALLATION

